



# VICTOR®

## Specialty Products

### Gas Manifold Systems & Accessories



STM	REF.	DATE	STM
		INITIAL RELEASE	
EO	E903	09-00	

ITEM NO.	DESCRIPTION
46	
45	
44	GAUGE 2" 600 PSI
43	PLASTIC PLUG 1/4 NPT
42	PLASTIC PLUG 1/2 NPT
41	PLASTIC SEAL
40	FACE SEAL
39	NUT (FACE SEAL)
38	O-RING
37	FACE SEAL FLANGE
36	INDICATOR LIGHT (GREEN)
35	INDICATOR LIGHT (RED)
34	NUT W/LOCKWASHER
33	SCREW
32	LIGHT BRACKET
31	HOSE
30	UNION TEE
29	
28	VENT TUBE ADAPTER
27	STREET ELBOW
26	BULKHEAD ADAPTER

**PROPRIETARY NOTICE**  
 This drawing contains designs and other information which are the property of VICTOR EQUIPMENT COMPANY. Except for rights granted by contract, this drawing may not be reproduced in whole or in part or used for the design, construction, manufacture or sale of equipment without the written permission of VICTOR EQUIPMENT COMPANY.

DRAWN BY	DATE	TITLE
R. BOYER	06-00	
CHECKED	D. PRYOR	9-00
APVD	L. TURNEY	9-00

DIMENSIONS ARE IN INCHES UNLESS NOTED

REMOVE ALL EDGES .005-.010  
 BREAK ALL SURFACES 128  
 MACHINED SURFACES WITH A GRINDING WHEEL  
 ALL FEATURES WITH A GRINDING WHEEL  
 MUST BE GRINDED WITH .005 (2.54)  
 TOLERANCES:  
 .001 .0010  
 .002 .0020  
 .005 .0050  
 ANGLES 45°

REF. DATA	MATERIAL	FINISH
10321		

**Table of Contents**

<b>I. Standards/How to Order</b>	
A. Industry Standards .....	2
B. Standard Features of Victor Manifold System .....	3
C. Determining the Right Manifold for Your Application .....	4
D. How to Order(Examples) .....	5
<b>II. Manifolds.....</b>	<b>6-23</b>
Dual.....	6
Simplex - SPLXR & SPLXL.....	6
Single - SSIN .....	7
Semi-Automatic - SAM.....	7
Liquid - LIQ .....	8
Header Extensions - HER & HEL .....	9
Station Drops .....	10-11
VM 2000/2100.....	12
VM 1000/1100.....	13
Inside view of VM Series Manifolds .....	14
How to Order (VM Series Manifolds) .....	15
PDS 600 Switchover Manifold .....	16-17
PDS 500 Switchover Manifold .....	18-19
VHP 2100/2000 High Purity Manifold .....	20-21
HPRB & HPLB Brass Headers .....	22
HPRS & HPLS Stainless Steel Headers.....	23
<b>III. Manifold Accessories .....</b>	<b>24-27</b>
Pressure Switches .....	24
Alarms.....	24
Bypass Valves and Ball Valves .....	25
Hydraulic Flash Arrestors.....	25
Wall Brackets, Floor Stands, Manifold Stands .....	26
Gas Service Labels & Placards .....	26
Pigtails .....	26
Valves.....	27
Union Fittings & Adaptors .....	27
<b>IV. Station Regulators .....</b>	<b>11 &amp; 28</b>
<b>V. Line Regulators.....</b>	<b>29</b>
<b>VI. Flowmeters.....</b>	<b>30</b>
<b>VII. Manifold Regulator Chart, FlowData &amp; Performance Data .....</b>	<b>31-33</b>
<b>VIII. Piping The Shop.....</b>	<b>34-38</b>
Gas & Cylinder Selection .....	34
Configurations.....	35
Pipe Sizing Data .....	36
Piping Systems Gas Flow & Pressure Data.....	37
Dimensions of center section and header.....	38

Victor Manifold Systems meet or exceed the following industry standards:

### Industry Standards

- Compressed Gas Association, Pamphlets V-1, E-1 and G-1
- American National Standards Institute, Pamphlet B-57.1
- Canadian Standards Association, Pamphlet B-96
- National Fire Protection Association, Pamphlets NFPA-51
- Underwriters Laboratories, Pamphlet UL407

### Components which are U.L. Listed:

- Victor Manifolds \*
- Primary Regulators
- Line Regulators
- Station Regulators
- Pressure Switches
- Flash Arrestors (in-line)
- Master Valves
- Alarm Systems (Pending)



### Components which are FM Listed:

- Hydraulic Flash Arrestors
- Pressure Switches

### Components which are CSA Approved:

- Pressure Switches

\*Nitrous Oxide manifolds are UL listed, industrial use only.

### Victor<sup>®</sup> Standard / Features

- Easy to Order, User Friendly Model Number System.
- Brazed Connections on all piping where possible to minimize the risks of leaks through threaded connections.
- 100% Tested.
- Shipped Complete. All manifolds come complete with adjustable regulator, brazed brass headers, pigtails with check valves (rigid or flexible depending on gas service), relief valves, and wall brackets.
- All systems designed to provide expandability in the event of future growth requirements (except Dual systems).
- All manifolds cleaned for oxygen service.
- The accuracy and dependability of Victor Regulators.
- Two Year Warranty.
- Worldwide Field Sales and Technical Support.
- Manifolds greater than six (6) stations per header are shipped in six (6 *maximum*) station sections.

**For Manifold questions call**

**1-800-569-0547**

**UNITED STATES CUSTOMER SERVICE**

**Phone: 1-800-569-0547 • FAX: 1-800-569-0549**

For International & Canada see back cover.



**MAKE A COPY OF THIS PAGE. KEEP THIS AS A MASTER.****Determining the right manifold for you application (Checklist)**

- 1) What is the application that the manifold will service? \_\_\_\_\_
- 2) What gas is required for your application? \_\_\_\_\_  
(ie. Oxygen, Nitrogen, Acetylene, etc.)
- 3) What CGA connection is used for this gas service? \_\_\_\_\_  
(ie. 540, 320, 510, etc.)
- 4) Do you require automatic or manual gas control? \_\_\_\_\_
- 5) What is the configuration required? Standard or Special? If Special, please indicate type and the actual dimensions of the area in which the manifold will be located. \_\_\_\_\_
- 6) Required line delivery pressure? (PSIG) \_\_\_\_\_
- 7) Volume Requirements:  
SCFH per month: \_\_\_\_\_  
Peak Flow Rate: \_\_\_\_\_  
CF Size of Cylinders to be Used: \_\_\_\_\_  
# days required between cylinder change: \_\_\_\_\_  
Total # of Cylinders on the manifold: (see below) \_\_\_\_\_
- 8) Installation: Inside or Outside? \_\_\_\_\_  
(Systems used outside must be shielded from direct weather contact.)
- 9) Accessories Required:
 

_____ Pressure Switch	Type:	_____
_____ Alarm System	Type:	_____
_____ Hydraulic Flash Arrestor		_____
_____ Hydraulic Flash Arrestor Stand		_____
_____ Cylinder Brackets	Type:	_____
_____ Gas Service Labels	Type:	_____
_____ Line Regulators	Type:	_____
_____ Station Regulators	Type:	_____
_____ Flowmeters	Type:	_____
_____ Station Drops	List:	_____
_____ Other (s)		_____

**Cylinder Formula****Cylinder Volume** = CF of Cylinder Less Residual Gases.**CF/Day/Station** = (CFH/Station) X (# Hours/Day) X Duty Cycle**CF/Day** = (CF/Day/Station) X (# Stations)
$$\frac{\text{CF/Day}}{\text{Cylinder Volume}} = \text{Cylinders/Day}$$

$$\frac{\text{Planned Cylinders/Header}}{\text{Cylinder Day}} = \text{Days/Header X \# of Headers}$$

$$\text{Maximum Days/Header X \# of Headers Days Between Deliveries}$$

Victor Manifold Systems are designed to make your ordering experience simple and easy to understand. Despite a product line which appears to be complex, this ordering system will allow you to get the right product to you or your customer.

The key to ordering is having the right information on what your needs are for the particular application. We have thus provided a checklist (p. 4) of the key information you will need to make the ordering process trouble-free. Should you require additional information, please contact our Customer Service Department at (US) 1-800-569-0547.

## Manifold Ordering Matrix

Gas Service	Center Section*	Regulator	Header (R)	Header (L)	Pigtail	Options
Acetylene	Dual	<b>Single Stage</b> SR450MD	<b>Right Side</b> <b>Wall Mount</b>	<b>Left Side</b> <b>Wall Mount</b>	<b>See Page 26 for Details.</b>	<b>00</b> With Line Regulator
Air	<b>SP LXR</b> (Right Inlet)	SR450ME	(RW = right side wall mount)	(LW = left side wall mount)		<b>02</b> Without Pipe Line Relief
Argon		SR452MD				
CO <sub>2</sub>	<b>SP LXL</b> (Left Inlet)	SR453MD	1RW	1LW		
Helium		SR460MA	2RW	2LW		
Hydrogen	<b>SSIN</b>	<b>High Flow</b> SR700MD	3RW	3LW		
Nitrogen		SR700ME	4RW	4LW		<b>03</b> With Alarm & Switch
Methane	<b>SAM</b>	SR710MA	5RW	5LW		
Nitrous Oxide	<b>Liquid</b>	SR711MB	6RW	6LW		
Oxygen		SR711MD	7RW	7LW		<b>04</b> With Alarm Switch Visual Only
Propane		<b>Two Stage</b> VTS450MD	8RW	8LW		
Propylene		VTS450ME	<b>Stand Mount</b>	<b>Stand Mount</b>		<b>09</b> With Hydraulic Flash Arrestor
		VTS452MD	(RS = right side stand mount)	(LS = left side stand mount)		
		VTS452ME	2RS	2LS		
		<b>High Pressure</b> SR4MF-996	4RS	4LS		<b>10</b> Without Hydraulic Flash Arrestor
		SR4MF-997	6RS	6LS		
		SR4MG-996	8RS	8LS		
		SR4MG-997	10RS	10LS		
		SR4MJ-996	12RS	12RS		
		SR4MJ-997				

\*Refer to the manifold selection section (p. 6) for detailed descriptions of all Victor manifolds and their applications.

## Step by Step Ordering Example

- Step 1** Identify the gas service. (Ex. Acetylene)
- Step 2** Center Section - locate the model in the catalog that best suits your needs. (Ex. SSIN - one side in use with other in reserve. Service may be interrupted.)
- Step 3** Select regulator for the flow rates and gas service. (Ex. Acetylene - SR460MA, SR710MA are available for acetylene service.)
- Step 4** Determine whether your needs require wall or stand mount and how many different cylinders per side (if applicable). (Ex. 2 RW & 2LW - 2 right hand wall mount and 2 left hand wall mount)
- Step 5** Determine length of pigtail needed and CGA connection. Use chart on Page 26 (Ex. 510 x 24" pigtail flex with CV & FA.)
- Step 6** Any options that are needed for the system. (Ex. With 300 SCFH flash arrestors and stand needed)

### ORDERING EXAMPLE:

**Acetylene - SSIN - SR460MA - 2RW-2LW - 510 - 24 FTCVFA - List Options**

## Applications

The Victor Dual manifold system is designed for those in need of basic manifolding. This manifold can provide two cylinder service for applications such as service stations, maintenance departments and other situations requiring simple manifolding. These are non-expandable systems with a maximum of two cylinders in service at one time.

## Design and Construction

- Open Style Manifold
- Choice of Regulators - See page 31
- Individual Station Shut-off Valves
- 3/4" NPT(F) Outlet
- Headers (7/8" brass pipe with bar stock tees)
- Brazed construction for maximum leak prevention
- Pigtails (check valves are standard)
  - 24 inch rigid for Hydrogen, Helium & N<sub>2</sub>O
  - 24 inch flexible for all other gases.
  - Acetylene models equipped with dry flash arrestors.
- Wall mount only
- 200 # Relief Valve to protect downstream piping (except fuel gas)



Basic Dual Model



## Performance Specifications

- Maximum inlet: 3000 PSIG
- Maximum Temperature Range: 140°F
- Minimum Temperature Range: 0° F

\* Dimensional data see page 38

# Simplex Manifold- SPLXR & SPLXL

## Applications

The Victor Simplex manifold system is designed to provide a single source of supply from one cylinder bank. Although these manifolds can be used as a primary source of gas, the typical application finds this model as a high pressure back-up system for liquid or bulk tank systems in industry and medical environments.

## Design and Construction

- Open Style manifold
- Choice of Regulators - See page 31
- Master Shut-off Valve
- Individual Station Shut-off valves
- 3/4" NPT(F) Outlet
- Headers (7/8" Brass Pipe with Bar Stock Tees)
  - 10 inch centers for Oxygen, Inert Gases & Hydrogen
  - 13 inch centers for Acetylene & Fuel Gases
- Brazed construction for maximum leak prevention
- End capped to accommodate future expansion needs
- Pigtails (check valves are standard)
  - 24 inch rigid for Hydrogen, Helium, & N<sub>2</sub>O
  - 24 inch flexible for all other gases.
  - Acetylene models equipped with dry flash arrestors.
- 200 # Relief Valve to protect piping (except fuel gas)
- Right & left hand inlets available
- Wall or stand mount available
- Acetylene and propane systems with two or more stations are shipped with a hydraulic flash arrestor-300 SCFH



Basic Simplex Model

## Performance Specifications

- Maximum inlet: 3000 PSIG
- Maximum Temperature Range: 140°F
- Minimum Temperature Range: 0°F

\* Dimensional data see page 38

## Single Manifold - SSIN

### Applications

The Victor Single manifold system is designed to provide a dual source of supply via a primary and reserve bank of cylinders. This manifold can provide effective service to any application in which down-time is not a problem. Once the primary bank has been depleted the reserve bank can be manually activated to return the system to working status.

### Design and Construction

- Open Style Manifold
- Choice of regulators - See page 31
- Master Shut-off Valves
- Individual Station Shut-off valves
- 3/4" NPT(M) Outlet
- Headers (7/8" brass pipe with bar stock tees)
  - 10 inch centers for Oxygen, Inert Gases & Hydrogen
  - 13 inch centers for Acetylene & Fuel Gases
- Brazed construction for maximum leak prevention
- End capped to accommodate future expansion needs
- Pigtailed (check valves are standard)
  - 24 inch rigid for Hydrogen, Helium, & N<sub>2</sub>O
  - 24 inch flexible for all other gases.
  - Acetylene models equipped with dry flash arrestors.
- Acetylene and propane systems with two or more stations, are shipped with a hydraulic flash arrestor - 300 SCFH
- Pressure switch port included, 1/4" NPT(F)
- Wall or stand mount available
- 200 # Relief Valve to protect piping (except fuel gas)

\* Dimensional data see page 38

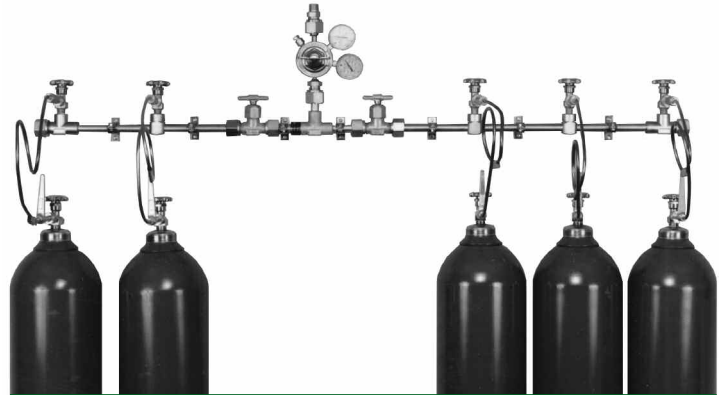

**Basic Single Model**

### Performance Specifications

- Maximum inlet: 3000 PSIG
- Maximum Temperature Range: 140°F
- Minimum Temperature Range: 0°F

### Applications

## Semi Automatic Manifold - SAM

The Victor Semi-Automatic manifold system is designed to provide an uninterrupted supply to any application requiring no down-time. As the primary supply is depleted a reserve supply is waiting to automatically begin service. Through pressure differential the switchover takes place without interruption of service, once depleted the primary bank can be replaced and becomes the new reserve bank.

### Design and Construction

- Open Style Manifold
- Choice of regulators - See page 31
- Adjustable Line Regulator (except for fuel gas)
- Master Shut-off Valves
- Individual Station Shut-off Valves
- 3/4" NPT(M) Outlet
- Headers (7/8" brass pipe with bar stock tees)
  - 10 inch centers for Oxygen, Inert Gases & Hydrogen
  - 13 inch centers for Acetylene & Fuel Gases
- Brazed construction for maximum leak prevention
- Low Pressure Side - Black Pipe
- End capped to accommodate future expansion needs
- Pigtailed (check valves are standard)
  - 24 inch rigid for Hydrogen, Helium, & N<sub>2</sub>O
  - 24 inch flexible for all other gases.
  - Acetylene models equipped with dry flash arrestors.
- Acetylene and propane systems with two or more stations, are shipped with a hydraulic flash arrestor - 300 SCFH
- Pressure switch port included, 1/4" NPT(F)
- Wall or stand mount available
- 200 # Relief Valve to protect piping (except fuel gas)

\* Dimensional data see page 38

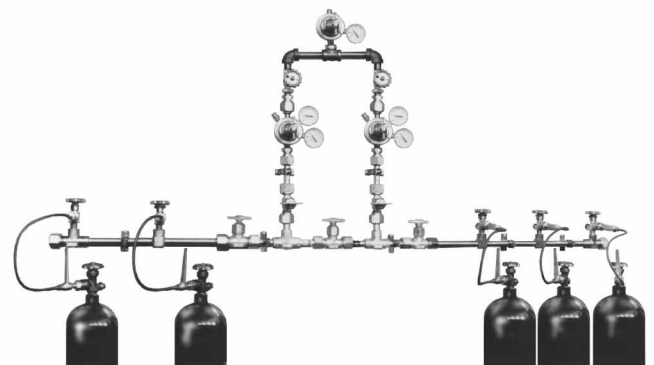

**Basic SAM Model**

### Performance Specifications

- Maximum inlet: 3000 PSIG
- Minimum pressure differential between primary & reserve bank is +/- 20 psig (+/- 5 PSIG Acetylene)
- Maximum Temperature Range: 140°F
- Minimum Temperature Range: 0°F

## Liquid Manifold - LIQ

Designed for applications with "low flow rates", this liquid/high pressure back-up manifold prevents excessive product loss. For applications with sufficient volume for liquid usage.

### Design and Construction

- Open style manifold
- LC700 series regulator L.P. side See page 31
- SR450 series backup regulator H.P. side
- Adjustable Line Regulator downstream
- 3/4"NPT(F) Outlet
- High Flow Relief Valves
- Master shut off valve (H.P.)
- Individual station shut-off valves
- Headers (H.P.)  
(7/8" brass pipe with bar stock tees)  
- 10 inch centers for O<sub>2</sub> & other Inerts
- Brazed Construction for maximum leak protection
- Pressure switch port included on H.P. side, 1/4" NPT(F)
- End capped to accommodate future expansion needs
- 200# relief valve to protect piping

### Performance Specifications

- Maximum Inlet: 400 PSIG low pressure bank  
3000 PSIG high pressure bank
- Maximum Delivery: 200 PSIG
- Minimum Pressure Differential +/- 20 PSIG
- Maximum Temperature: 140°F
- Minimum Temperature: 0°F

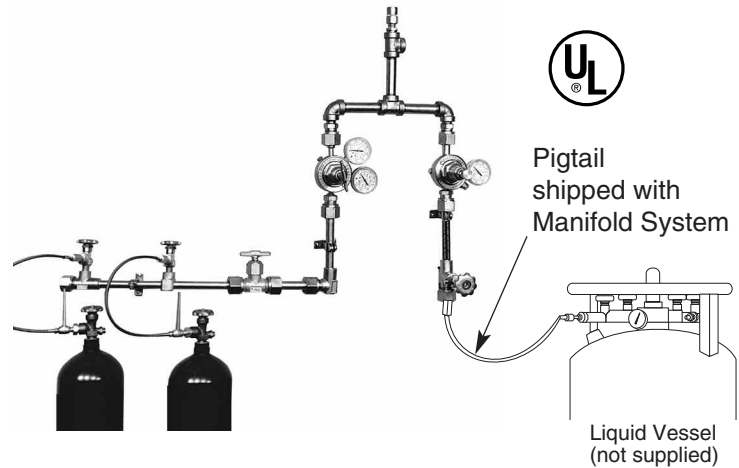

### Model Shown: LIQ-IRW-2LW-580-36FTCV

Liquid is always on the right.

Dimension - Overall Length- Height 30 Inches				
# of Cylinders	Control Only	3 X 1	6 X 2	8 X 3
Inches	30.0	67.4	97.4	117.4
Centimeters	76.2	171.2	247.4	298.2

Model No.	Gas Service	PSIG Delivery Range
LIQ	540 OXYGEN	10 - 200
	580 INERTS	
	320 CO <sub>2</sub>	

### Portable Bulk Liquid Containers

#### What you need to know?

- \*Vaporization Rate:** Typically 250 to 350 SCFH
- Outlet Pressure:** Typically 125 PSIG  
300 PSIG Models are also available
- Evaporization Rate:** Up to 3% per day will vent to atmosphere
- Temperature:** Vaporizing gas is very cold.  
Approximately -300° Fahrenheit.
- Warning:**  
Multiple liquid cylinder manifolds MUST have the pressure building regulator of each vessel set at the same pressure to insure proper cylinder withdrawal.



All Victor Manifolds are expandable to meet changing application requirements. Victor header extensions are easy to add to your existing Victor manifold system.

### Design and Construction

- 3000 PSIG Rated
- Brazed brass construction for maximum leak protection
- Right or left side expansions.
- 1" x 1 1/2" NPS Connections
- End capped to accommodate future expansion needs. (Option #08)
- Pigtails (Check valves are standard)
  - 24 inch rigid for Hydrogen, Helium & N<sub>2</sub>O
  - 24 inch flexible for all other gases
  - Acetylene models equipped with dry flash arrestors
  - High purity brass and stainless models also available. Contact Victor Customer Service.

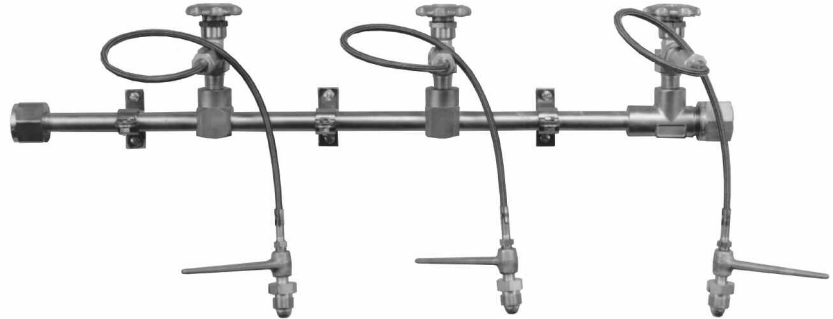

**Model Shown: HER-3\* (Right Side)**

\* Includes valves and pigtails as shown above

Looking at the manifold.

**HEL** = Left Side **HER** = Right Side

Dimension - Overall Length				
# of Cylinders	1	2	3	4
Inches	17.4	27.4	37.4	47.4
Centimeters	44.1	69.5	94.9	120.4

**Expansion Elbow**



EXPANSION ELBOW - 90° ANGLE 1"-1-1/2 NPS (F) X 1"-1-1/2 NPS (M)	
Part No.	Length
1109-0503	4-1/2" LONG
1109-0501	8-1/3" LONG
1109-0502	11-1/3" LONG

For Manifold questions call

**1-800-569-0547**

# Station Drops

Victor offers Station drops in 3 various configurations - single, double, and quad systems. Each system can be outfitted for various gas service with the proper station valve or outlet valve.

Manifolds  
Station Drops



**Single (18.5")**



**Double (30.5")**



**Quad (30.5")**

## Oxygen

Description	Model	Part Number
Single Station Drop with Station Valve 7/8" - 14 RH outlet CGA 024	SD - 1 - 024	1126 - 0003
Double Station Drop with Station Valve 7/8" - 14 RH outlet CGA 024	SD - 2 - 024	1126 - 0007
Quadruple Station Drop with Station Valve 7/8" - 14 RH outlet CGA 024	SD - 4 - 024	1126 - 0011
Single Station Drop with Ball Seat Valve 9/16" - 18 RH outlet CGA 022	SD - 1 - 022	1126 - 0018
Double Station Drop with Ball Seat Valve 9/16" - 18 RH outlet CGA 022	SD - 2 - 022	1126 - 0020
Quadruple Station Drop with Ball Seat Valve 9/16" - 18 RH outlet CGA 022	SD - 4 - 022	1126 - 0015

## Fuel Gas

Description	Model	Part Number
Single Station Drop with Station Valve 7/8" - 14 LH outlet CGA 025	SD - 1 - 025	1126 - 0004
Double Station Drop with Station Valve 7/8" - 14 LH outlet CGA 025	SD - 2 - 025	1126 - 0008
Quadruple Station Drop with Station Valve 7/8" - 14 LH outlet CGA 025	SD - 4 - 025	1126 - 0012
Single Station Drop with Ball Seat Valve 9/16" - 18 LH outlet CGA 023	SD - 1 - 023	1126 - 0019
Double Station Drop with Ball Seat Valve 9/16" - 18 LH outlet CGA 023	SD - 2 - 023	1126 - 0021
Quadruple Station Drop with Ball Seat Valve 9/16" - 18 LH outlet CGA 023	SD - 4 - 023	1126 - 0016

**W/ Station Valve**

**W/ Ball Valve**

Description	Ordering Info	Part Number
Single Station Drop with Station Valve <b>CGA 034</b>	SD - 1 - 034	1126 - 0005
Double Station Drop with Station Valve <b>CGA 034</b>	SD - 2 - 034	1126 - 0009
Quadruple Station Drop with Station Valve <b>CGA 034</b>	SD - 4 - 034	1126 - 0013

Description	Ordering Info	Part Number
Single Station Drop with Ball Seat Valve 5/8" - 18F RH <b>CGA 032</b>	SD - 1 - 032	1126 - 0006
Double Station Drop with Ball Seat Valve 5/8" - 18F RH <b>CGA 032</b>	SD - 2 - 032	1126 - 0010
Quadruple Station Drop with Ball Seat Valve 5/8" - 18F RH <b>CGA 032</b>	SD - 4 - 032	1126 - 0014

**Station Regulators and Flowmeters are available.**

<b>250 Series (Light Duty)</b>					
<u>Oxygen</u>	<u>Delivery Range (psi)</u>	<u>Part Number</u>	<u>Fuel Gas</u>	<u>Delivery Range (psi)</u>	<u>Part Number</u>
S 250 B - 024	0-40	0781-1261	S 260A - 025 (Acet & LP)	0-15	0781-1263
S 250 D - 024	0-125	0781-1262	S 261C - 025 (LP only)	0-80	0781-1264
			S 261D - 025 (LP only)	0-125	0781-1265

<b>350 Series (Medium / Heavy Duty)</b>					
<u>Oxygen</u>	<u>Delivery Range (psi)</u>	<u>Part Number</u>	<u>Fuel Gas - rear entry</u>	<u>Delivery Range (psi)</u>	<u>Part Number</u>
S 350 BR - 024 (rear)	0-40	0781-2508	S 360AR - 025 (Acet)	0-15	0781-2510
S 350 DR - 024 (rear)	0-125	0781-2509	S 361BR - 025 (LP only)	0-40	0781-2511
S 350 B - 024 (side)	0-40	0781-2503	S 361CR - 025 (LP only)	0-80	0781-2487
S 350 D - 024 (side)	0-125	0781-2502			
			<u>Fuel Gas - side entry</u>		
			S 360A - 025 (Acet)	0-15	0781-2504
			S 361B - 025 (LP only)	0-40	0781-2501
			S 361D - 025 (LP only)	0-125	0781-2513

<b>700 Series (Extra Heavy Duty)</b>					
<u>Oxygen</u>	<u>Delivery Range (psi)</u>	<u>Part Number</u>	<u>Fuel Gas - side entry</u>	<u>Delivery Range (psi)</u>	<u>Part Number</u>
L 700 D - 750 (side) (3/4" NPT inlet)	0-125	0780-1299	L 711 C - 750 (LP gas) (3/4" NPT inlet)	0-80	0780-1298
L 700 E - 750 (side) (3/4" NPT inlet)	0-200	0780-1300			

Other Line and Station regulators are available.  
See page 28 & 29 for further selection.

Manifolds (VM)  
Headers/Heater

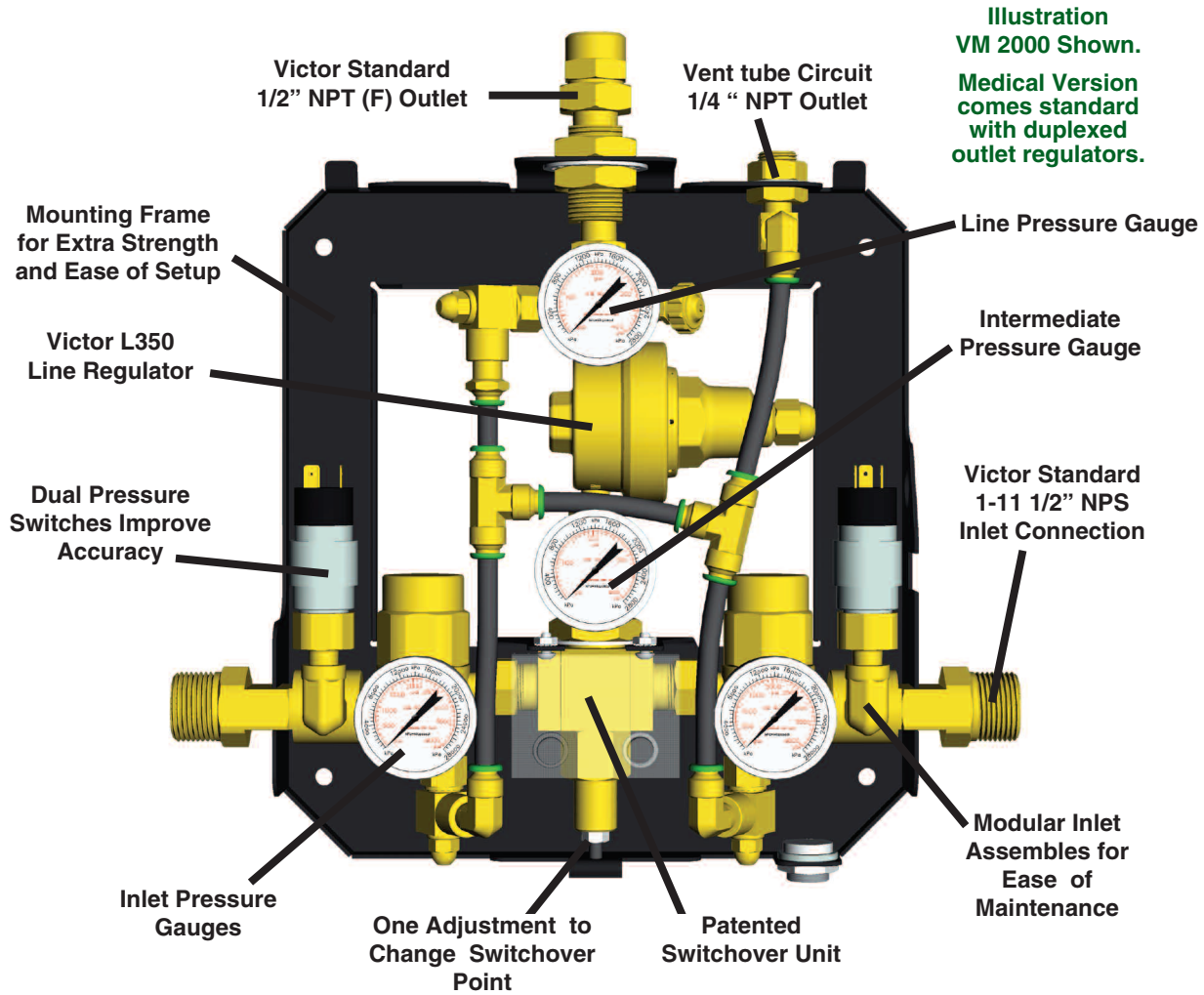

**Illustration VM 2000 Shown. Medical Version comes standard with duplexed outlet regulators.**

## Manifold Headers and Heater

VM Series Manifold Shown with Headers and Heater. →

↓ VM Series Manifold Shown with Compact Headers





## How To Order - Enclosed Style VM Series Manifolds

Victor Manifold Systems are designed to make your ordering experience simple and easy to understand. Despite a product line which appears to be complex, this ordering system will allow you to get the right product to you or your customer.

The key to ordering is having the right information on what your needs are for the particular application. We have thus provided a checklist below of the key

information you will need to make the ordering process trouble-free.

Should you require additional information, please contact our Customer Service Department at (US) 1-800-569-0547. Additionally, we offer a worldwide network of trained District and Regional Managers who would be glad to assist you.

### VM Series Manifold Ordering MODEL NUMBER SYSTEM

**GAS XXXXX - XXX - XXX - XXX - XXXXXXXX - XX**

Gas Service	Center Section	Header (RIGHT)	Header (LEFT)	CGA	Length/Style	Options
Acetylene	VM2000 (Industrial)	Wall Mount 1RW	Wall Mount 1LW	Acetylene 200, 300, 520, 510	24FTCVFA 24" Flexible Teflon Lined Check Valve Flash Arrestor	03 With Alarm & Switch (Audio & Visual)
Air	VM2100 (Medical)	2RW	2LW	Air (Industrial) 590	24FS 24" Flexible ST. ST. Lined	05 With 500W Heater
Argon	VM1000 (Industrial Liquid)	4RW	4LW	Air (Breathing) 346		06 With 1000W Heater
Carbon Dioxide	VM1100 (Medical Liquid)	5RW	5LW	Argon 580	24RC 24" Rigid Copper	09 With 300 CFH Hydraulic Flash Arrestor
Helium	VM2010 (C <sub>2</sub> H <sub>2</sub> )	Stand Mount 2RS	Stand Mount 2LS	Carbon Dioxide 320		
Hydrogen	VM2011 (LP)	4RS	4LS	Helium 580	24FTL 24" Flexible Teflon Lined	10 W/O Hydraulic Flash Arrestor
Nitrogen	VM2012 (H <sub>2</sub> Methane)	6RS	6LS	Hydrogen 350		VM1000/1100 72FPCV 72" Flexible Polyethylene Check Valve
Methane		10RS	10LS	Nitrogen 580,		20 Center Section Stand
Nitrous Oxide		12RS	12LS	Methane 350		
Oxygen		VM1000/1100 1RWC	VM1000/1100 1LWC	Nitrous Oxide 326		
Propane		2RWC	2LWC	Oxygen 540		
		3RWC	3LWC	Propane 510		

#### Ordering Example #1:

**Acetylene VM2000-2RW-2LW-580-24FTCV**

VM2000 Manifold with 2 cylinders per side,  
CGA 580 connections on 24" flexible  
Teflon lined pigtails with check valves.

#### Ordering Example #2:

**Oxygen VM1000-1RWC-1LWC-540-72FPCV**

VM1000 Manifold with 1 cylinder per side,  
CGA 540 connections on 72" flexible  
pigtails with check valves.

# VM2000 Series High Pressure Cylinder Automatic Manifold System

**VICTOR**  
Specialty Products

The Victor VM2000 Series is designed to be a fully automatic system for use with high pressure cylinders. The manifold gives an uninterrupted supply of gas as the primary bank of cylinders is depleted. At a preset pressure, the manifold automatically switches to the reserve bank. The system eliminates the need for the operator to change switches or pressure upon cylinder depletion. The manifold comes with Victor's two-year warranty, while maintaining a five year warranty on the switchover mechanism itself.



**VM2000 Industrial Shown**

## Safety Standards and Codes

- Compressed Gas Association (Pamphlets V-1, E-1, G-1)
- American National Standards Institute (Pamphlets B-57-1)
- National Fire Protection Association (Pamphlets NFPA-51)
- UL listed component regulators and valves
- Medical units comply with National Fire Protection Association (Pamphlets NFPA-99C)

## Performance Specifications

Maximum Inlet                    3000 PSIG  
 Maximum Temperature      140° F (degrees)  
 Minimum Temperature      0° F (degrees)

## Design & Construction Features

- **Frame mounted design with removable cover**
  - 12.8"W x 14.0"H x 5"D
  - Powder coated steel mounting frame
  - Durable ABS plastic cover
  - Cover draw latch is padlockable for security
  - Wall or stand mount available
  - 1/2" NPT (F) outlet connection
  - Inlet size: 1-11 1/2" NPS (M)
- **Fully automatic changeover**
  - Patented switchover unit
  - Does not require power to change over
  - Dual pressure switch design prevents false readings
- **Adjustable delivery pressure**
  - 0-200 PSIG for Oxygen, Air, Inert, CO<sub>2</sub>
  - 0-70 PSIG for medical models except Nitrogen
  - Line, supply, reserve and intermediate pressure gauge
- **High flow capacity**
  - 3500 SCFH air @ 70° F
- **Ease of repair**
  - Removeable cover for easy access to internal components
- **Electrical requirements**
  - 24 VAC service - cabinet lights and alarm
  - 115/24 VAC power supply included
  - In case of power failure system continues to operate.
- **500W or 1000W heaters available** (500W standard for CO<sub>2</sub> and N<sub>2</sub>O service)
- **Models also available for Helium, Acetylene, LP Gas and Hydrogen/Methane**

Model	Description	Control Section Part Number
VM2000	Oxygen Fully Auto Cabinet	1125-1133
VM2000	Inert Gas Fully Auto Cabinet	1125-1134
VM2000	CO <sub>2</sub> Fully Auto Cabinet (w/500W heater)	1132-4189
VM2100	Medical Oxygen Fully Auto Cabinet	1125-1137
VM2100	Medical Nitrogen Fully Auto Cabinet	1125-1138
VM2100	Medical Compressed Air Fully Auto Cabinet	1125-1139
VM2100	Medical CO <sub>2</sub> Fully Auto Cabinet (w/500W heater)	1132-4190

U.S. Customer Care: 800-569-0547 / FAX 800-535-0557

Manifolds  
VM2000/2100

The Victor VM1000 Series is designed to be a fully automatic system for use with liquid cylinders. The manifold gives an uninterrupted supply of gas as the primary bank of cylinders is depleted. At a preset pressure, the manifold automatically switches to the reserve bank. The system eliminates the need for the operator to change switches or pressure upon cylinder depletion. The manifold comes with Victor's two-year warranty, while maintaining a five year warranty on the switchover mechanism itself. The 1000 Series models include an economizer circuit to help prevent reserve cylinders from wasting gas due to venting to atmosphere.



**VM1100 Medical Shown**

## Safety Standards and Codes

- Compressed Gas Association (Pamphlets V-1, E-1, G-1)
- American National Standards Institute (Pamphlets B-57-1)
- National Fire Protection Association (Pamphlets NFPA-51)
- UL listed component regulators and valves
- Medical units comply with National Fire Protection Association (Pamphlets NFPA-99C)

## Performance Specifications

Maximum Inlet                    500 PSIG  
 Maximum Temperature    140° F (degrees)  
 Minimum Temperature    0° F (degrees)

## Design & Construction Features

- **Frame mounted design with removable cover**
  - 12.8"W x 14.0"H x 5"D
  - Powder coated steel mounting frame
  - Durable ABS plastic cover
  - Cover draw latch is padlockable for security
  - Wall or stand mount available
  - 1/2" NPT (F) outlet connection
  - Inlet size: 1-11 1/2" NPS (M)
- **Fully automatic changeover**
  - Patented switchover unit
  - Economizer circuit
  - Does not require power to change over
  - Dual pressure switch design prevents false readings
- **Adjustable delivery pressure**
  - 0-200 PSIG for Oxygen, Air, Inert, CO<sub>2</sub> and N<sub>2</sub>O
  - 0-70 PSIG for medical models except Nitrogen
  - Higher delivery pressures require higher inlet pressures
  - Line, supply, reserve and intermediate pressure gauge
- **High flow capacity**
  - 3000 SCFH air @ 70° F

**Note: Flow rate is limited by the withdrawal rate of vaporized gas from liquid containers, as well as the number of containers in the system. Flow rate listed for reference only.**
- **Ease of repair**
  - Removeable cover for easy access to internal components
  - Face seal connections
- **Electrical requirements**
  - 24 VAC service - cabinet lights and alarm
  - 115/24 VAC power supply included
  - Alarm system optional, not required for manifold to operate.
  - In case of power failure system continues to operate

Model	Description	Control Section Part Number
VM1000	Oxygen Fully Auto Cabinet	1125-1127
VM1000	Inert Gas Fully Auto Cabinet	1125-1128
VM1000	CO <sub>2</sub> Fully Auto Cabinet	1125-4129
VM1100	Medical Oxygen Fully Auto Cabinet	1125-1130
VM1100	Medical Nitrogen Fully Auto Cabinet	1125-1131
VM1100	Medical N <sub>2</sub> O/CO <sub>2</sub> Fully Auto Cabinet	1125-1132



The **PDS 600** is an automatic switchover manifold system that changes between a primary side, or bank, and the secondary side using the pressure differential between the two sides of high pressure gas supply. The PDS 600 is designed to continuously supply the downstream process with high purity gas from two individual cylinders, or from two entire banks of cylinders manifolded together.

The PDS 600 is designed with an outlet regulator to maintain a constant downstream pressure. The PDS 600 is available with brass or with stainless steel bar stock regulators for use with high purity or corrosive gases.

### PDS 600 Features

- Metal-to-metal diaphragm seals.
- Helium leak rate of  $1 \times 10^{-9}$  scc/sec. All high purity regulators are inboard leak checked with a helium mass spectrometer.
- 2" dual scale gauges.
- Cartridge-type seat assemblies with 10 micron inboard filter.
- 180 degree lever with arrow indicates which side of the manifold is the active side.
- Rotating captured vent for remote venting of process gases (optional).
- Regulator bodies are mounted on rear bracket.
- Audible and visual alarms (optional).
- New control knob allows precise setting for maximum delivery. Locking is easily attained by pressing in the cap.

### PDS 600 Specifications

Maximum inlet pressure .....	3000 psig
Maximum delivery flow rate .....	See Performance Data
Outlet pressure ranges .....	15 (2-15 psig)
	40 (2-40 psig)
	80 (4-80 psig)
	125 (5-125 psig)
Switchover Pressures .....	Right to Left Bank: 200 psig
	Left to Right Bank: 165 psig
Inlet & Outlet ports .....	1/4" NPT (F)
Temperature Operating Range .....	-40 to 140°F (-40 to 60°C)
Outlet pressure rise .....	PDS 600: None
Flow coefficient .....	$C_v = .05$
Weight .....	12 lbs (5.4 kgs)
Mounting Hole Spacing .....	8.5W x 2.5H

## Materials of Construction

### PDS 600 Brass

Body .....	Chrome-plated, Brass bar stock
Spring housing cap .....	Chrome-plated Brass
Diaphragm .....	316L Stainless Steel
Nozzle .....	Brass
Seat .....	PCTFE™
Seals .....	Viton™
Poppet .....	Brass bar stock
Inboard Filter .....	10 Micron Sintered S.S.
Seat Return Spring .....	316L Stainless Steel
Pressure Adjusting Spring .....	Heat-treated Spring Steel
Adjusting Knob .....	Polypropylene

### PDS 600 Stainless Steel

Body .....	316L S.S. Bar Stock
Spring housing cap .....	Chrome-plated Brass
Diaphragm .....	316L Stainless Steel
Nozzle .....	316L Stainless Steel
Seat .....	PCTFE™
Seals .....	Teflon™
Poppet .....	316L Stainless Steel
Inboard Filter .....	10 Micron Sintered S.S.
Seat Return Spring .....	316L Stainless Steel
Pressure Adjusting Spring .....	Heat-treated Spring Steel
Adjusting Knob .....	Polypropylene



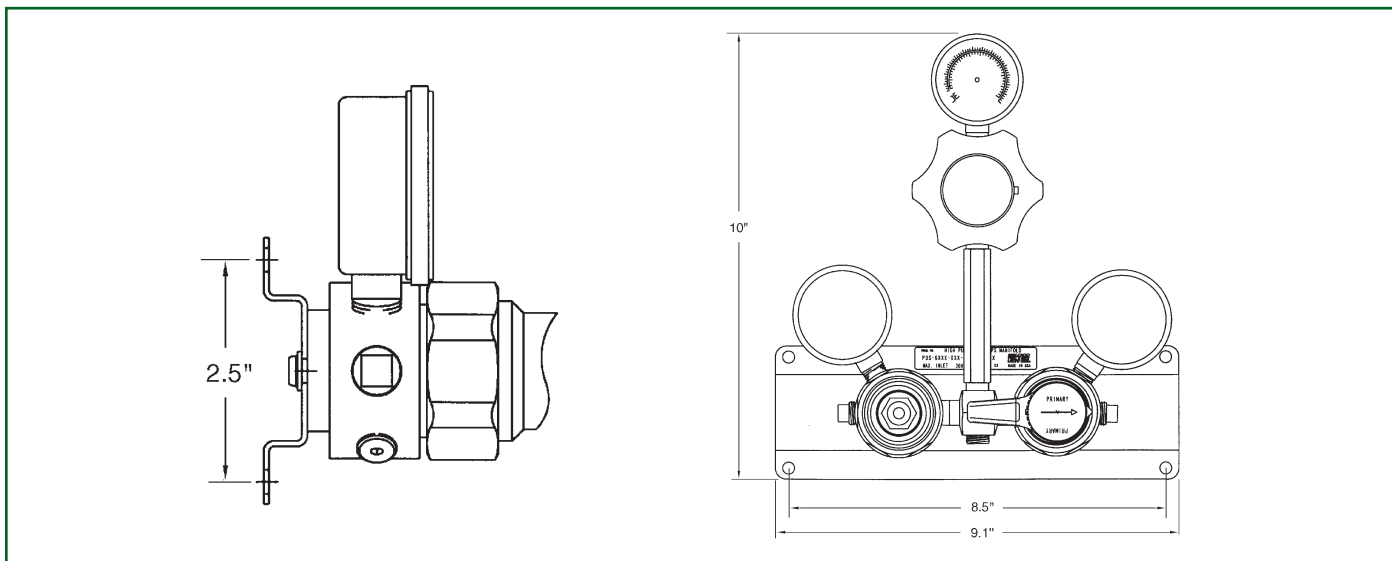

## PDS 600 Performance Data

PDS 600 Flow Data

### Flow vs Outlet Pressure

Inlet Pressure  
(Air @ 70°F)

— 2000 psig  
- - - 200 psig

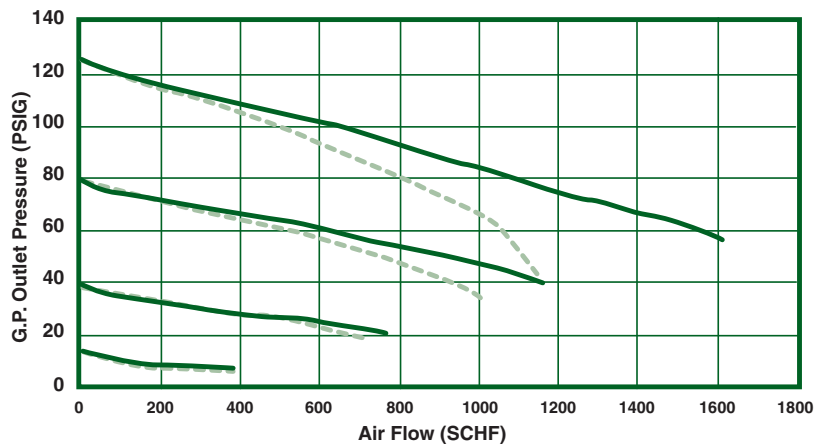

## ORDERING: Model Number System

XXXX	XXX	XXX	XXX	XXX	XX
Center Section	Delivery Pressure	Header Right	Header Left	CGA	Stainless Steel Pigtail
PDS 600B (Brass)	15 40 80 125	1 RW 2 RW 3 RW 4 RW 6 RW See note *	1 LW 2 LW 3 LW 4 LW 6 LW See note *	<b>Brass</b> 580 320 590 346 350 540 <b>Stainless Steel</b> 240 660 330 705	24", Flex 36", Flex See note †

### Ordering

Example: PDS-600B-40-1RW-2LW-350-36

PDS 600B manifold w/ 40 psi delivery pressure, 1 header right, 2 header left, CGA 350 brass inlet, and 36" flex stainless steel pigtail

\* Optional header configurations are available.

† Standard pigtails are stainless steel lined and include a check valve.

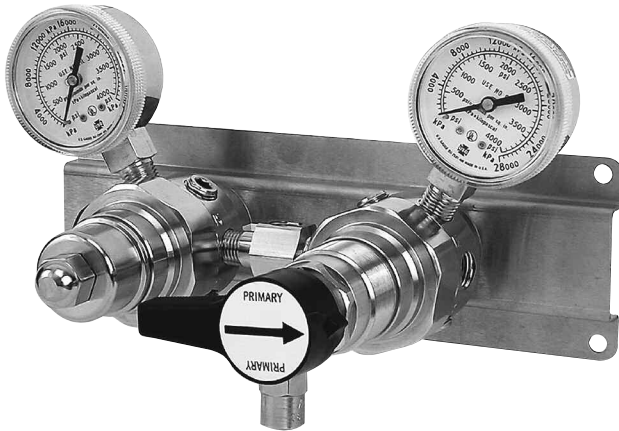

The **PDS 500** is an automatic switchover manifold system that uses the pressure differential between each side, or bank, of the manifold to determine which side is active. The PDS 500 is designed to continuously supply the downstream process with high purity gas from two individual cylinders, one primary and one secondary, or from a bank of cylinders manifolded together.

The PDS 500 is available with brass or stainless steel bar stock regulators for use with high purity or corrosive gases.

### PDS 500 Features

- Metal-to-metal diaphragm seals.
- Helium leak rate of  $1 \times 10^{-9}$  scc/sec. All high purity regulators are inboard leak checked with a helium mass spectrometer.
- 2" dual scale gauges.
- Cartridge-type seat assemblies with 10 micron inboard filter.
- 2" brass bar stock body regulators with ports for high and low pressure transducers or alarm switches.
- 180 degree lever with arrow indicates which side of the manifold is the active side.
- 360° rotating captured vent for remote venting of process gases. (optional)
- Regulator bodies are mounted on rear bracket.
- Audible and visual alarms (optional).

### PDS 500 Specifications

Maximum inlet pressure .....	3000 psig
Maximum delivery flow rate .....	See Performance Data
Outlet pressure ranges:	
Right Bank as Primary:	250 psig max.
Right Bank as Secondary:	165 psig min.
Left Bank Preset:	200 psig
Switchover Pressures .....	Right to Left Bank: 200 psig
	Left to Right Bank: 165 psig
Inlet & Outlet Ports .....	1/4" NPT (F)
Temperature Operating Range .....	-40 to 140°F (-40 to 60°C)
Outlet pressure rise .....	53 psig / 100 psig inlet decay
Flow coefficient .....	$C_v = .083$
Weight .....	8.5 lbs (3.8 kgs)
Mounting Hole Spacing .....	8.5W x 2.5W

## Materials of Construction

### PDS 500 Brass

Body .....	Chrome-plated, Brass bar stock
Spring housing cap .....	Chrome-plated Brass
Diaphragm .....	.316L Stainless Steel
Nozzle .....	Brass bar stock
Seat .....	PCTFE™
Seals .....	Viton™
Poppet .....	Brass bar stock
Inboard Filter .....	10 Micron Sintered S.S.
Seat Return Spring .....	.316L Stainless Steel
Pressure Adjusting Spring .....	Heat-treated Spring Steel
Adjusting Knob .....	Polypropylene

### PDS 500 Stainless Steel

Body .....	.316L S.S. Bar Stock
Spring housing cap .....	Chrome-plated Brass
Diaphragm .....	.316L Stainless Steel
Nozzle .....	.316L Stainless Steel
Seat .....	PCTFE™
Seals .....	Teflon™
Poppet .....	.316L Stainless Steel
Inboard Filter .....	10 Micron Sintered S.S.
Seat Return Spring .....	.316L Stainless Steel
Pressure Adjusting Spring .....	Heat-treated Spring Steel
Adjusting Knob .....	Polypropylene

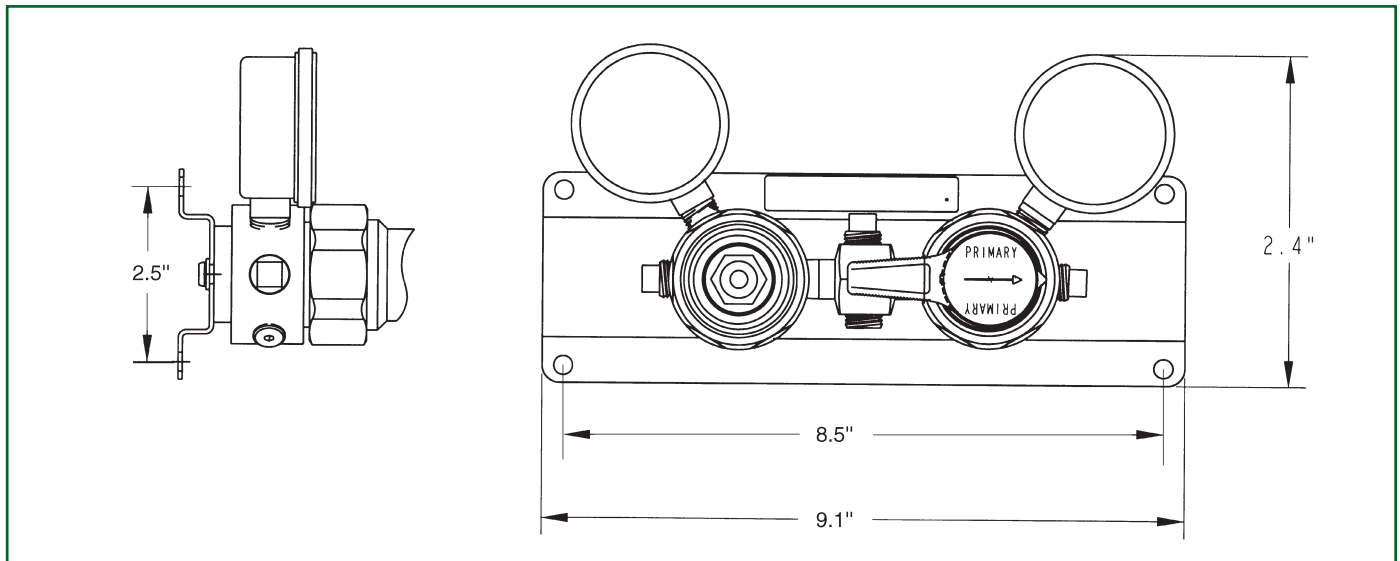

## PDS 500 Performance Data

PDS 500 Flow Data

### Flow vs Outlet Pressure

Inlet Pressure  
(Air @ 70°F)

— 2000 psig  
- - - 200 psig

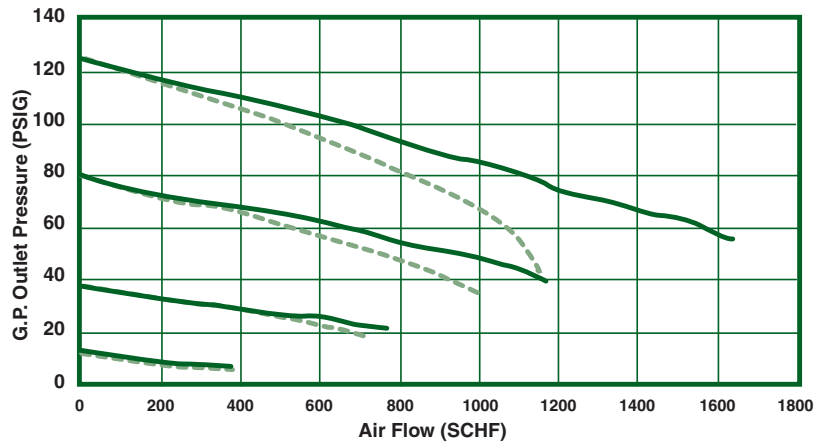

## ORDERING: Model Number System

XXXX	XXX	XXX	XXX	XX
Center Section	Header Right	Header Left	CGA	Stainless Steel Pigtail
PDS 500B (Brass)	1 RW 2 RW	1 LW 2 LW	Brass 580 320	24", Flex
PDS 500S (Stainless)	3 RW 4 RW 6 RW See note *	3 LW 4 LW 6 LW See note *	590 346 350 540 Stainless Steel 240 660 330 705	36", Flex See note †

### Ordering

Example: PDS-500B-40-1RW-2LW-350-36

PDS 500B manifold, 1 header right, 2 header left, CGA 350 brass inlet, and 36" flex stainless steel pigtail.

\* Optional header configurations are available.

† Standard pigtails are stainless steel lined and include a check valve.

# VHP 2100/2000 Switchover Manifold High Purity Switchover Manifold

**VICTOR**  
Specialty Products

Manifolds  
High Purity



**VHP 2100** manifold is a deluxe system for high purity gases. The system is highly recommended for laboratory and process plant applications where depletion of gas supply is unacceptable. The VHP 2100 is designed with an outlet regulator to maintain a constant downstream pressure. The system is available in brass or 316L stainless steel. In service and reserve indicator lights are standard on the VHP 2100 manifold.

**VHP 2000** manifold is the same manifold without the in service and reserve indicator lights.

## VHP 2100/2000 Features

- 500 Series barstock regulators - High Purity for critical applications.
- In service and reserve indicator lights standard. †
- Metal-to-metal seals for low helium leak integrity.
- Adjustable line regulator for constant delivery.
- Line regulator enclosed in box for tamper - resistant protection.
- Easy 180° lever to select primary gas source.
- VHP 2100 Model incorporates pressure switches for remote alarm activation to indicate gas depletion. †

† VHP 2100 model only

## VHP 2100/2000 Specifications

Maximum inlet pressure .....	3000 psig
Outlet pressure ranges .....	15 (2-15 psig)
	40 (2-40 psig)
	80 (4-80 psig)
	125 (5-125 psig)
Switchover Pressures.....	Right to Left Bank: 200 psig
	Left to Right Bank: 165 psig
Inlet & Outlet ports .....	1/4" NPT (F)
Temperature Operating Range .....	-40 to 140°F
	(-40 to 60°C)
Outlet pressure rise .....	None
Flow coefficient .....	C <sub>v</sub> = .05
Weight .....	30 lbs

## Materials of Construction

### VHP 2100/2000B Brass

Body .....	Chrome-plated, Brass bar stock
Spring housing cap .....	Chrome-plated Brass
Diaphragm .....	316L Stainless Steel
Nozzle .....	Brass
Seat .....	PCTFE™
Seals .....	Viton™
Poppet .....	Brass bar stock
Inboard Filter .....	10 Micron
Seat Return Spring .....	316L Stainless Steel
Pressure Adjusting Spring .....	Heat-treated Spring Steel
Adjusting Knob .....	Polypropylene
Enclosure .....	16 Gauge Powder Coated
Tubing .....	1/4" Copper
Fittings .....	Brass Tube

### VHP 2100/2000S Stainless Steel

Body .....	316L S.S. Bar Stock
Spring housing cap .....	Chrome-plated Brass
Diaphragm .....	316L Stainless Steel
Nozzle .....	316L Stainless Steel
Seat .....	PCTFE™
Seals .....	Teflon™
Poppet .....	316L Stainless Steel
Inboard Filter .....	10 Micron
Seat Return Spring .....	316L Stainless Steel
Pressure Adjusting Spring .....	Heat-treated Spring Steel
Adjusting Knob .....	Polypropylene
Enclosure .....	16 Gauge Powder Coated
Tubing .....	1/4" Stainless Steel
Fittings .....	Stainless Steel Tube



# VHP 2100/2000 Switchover Manifold High Purity Switchover Manifold

**VICTOR**<sup>®</sup>  
Specialty Products

Manifolds  
High Purity

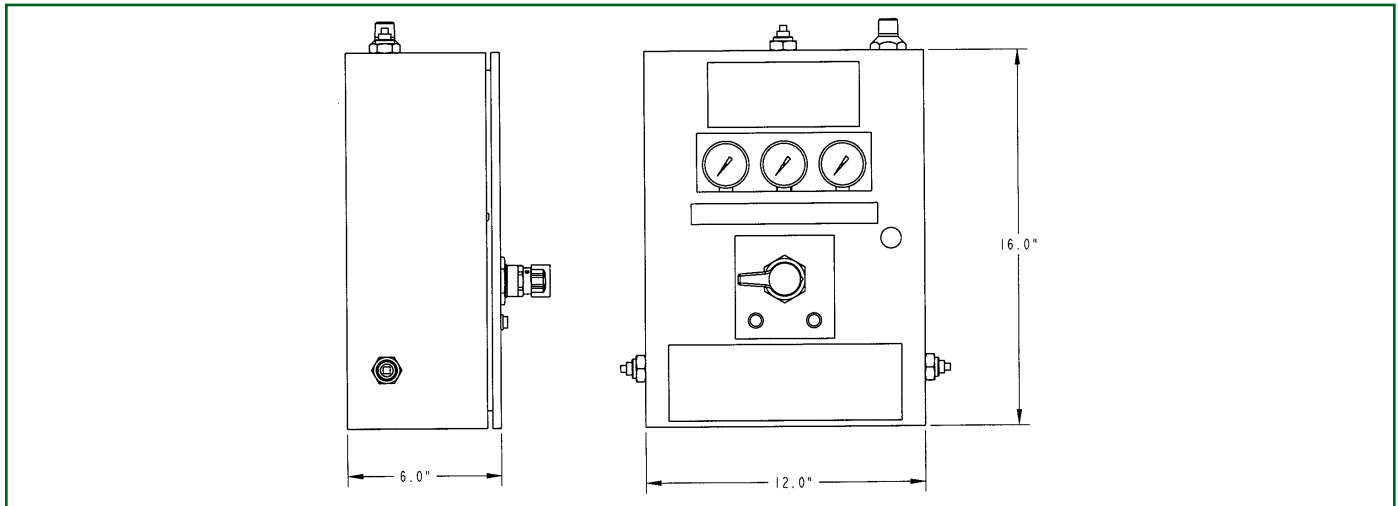

## VHP 2100/2000 Performance Data

### Flow vs Outlet Pressure

Inlet Pressure  
(Air @ 70°F)

———— 2000 psig

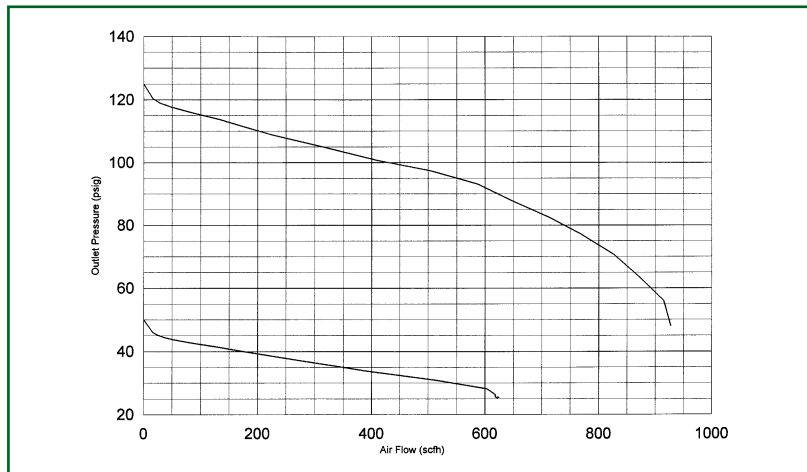

## ORDERING: Model Number System

XXX	XXXX	XXX	XXX	XXX	XX
CGA	Center Section	Delivery Pressure	Header Right	Header Left	Stainless Steel Pigtail
580	VHP 2000B (Brass)	15	1 RW	1 LW	24", Flex
590		40	2 RW	2 LW	36", Flex
350	VHP 2000S (Stainless)	80	3 RW	3 LW	See note †
320		125	4 RW	4 LW	
346	VHP 2100B (Brass w/lights)	300	6 RW	6 LW	
540			See note *	See note *	
240	VHP 2100S (Stainless w/lights)				
330					
660					
705					

\* Optional header configurations are available.

† Standard pigtails are stainless steel lined and include a check valve.



## HPRB & HPLB

### Brass Headers

Victor brass headers are designed for high purity non-corrosive gas applications where two or more cylinders are needed for supply critical processes.

The materials of construction will not off-gas and contaminate the gas stream. The design is highly resistant to inboard diffusion of atmospheric conditions. Flexible braided stainless steel pigtails, lined with stainless steel are standard.

### HPRB & HPLB Features

- Brazed construction for maximum leak protection.
- 7/8" O.D. brass pipe with bar stock tees.
- DRK packless diaphragm shut off valves.
- Flexible braided stainless steel pigtails, lined with stainless steel, with check valves.
- Rated for hydrogen and helium service.
- Easily connected to PDS and VHP.

### Materials of Construction

Pipe .....	Brass
Tees .....	Brass Bar Stock
Valves .....	Packless Diaphragm
Pigtails .....	Stainless Steel Braided, Stainless Steel Lined

### HPRB & HPLB Specifications

Maximum inlet pressure .....3000 psig  
 Inlet connections are standard CGAs.  
 Outlet connections are standard CGAs.

### Typical Applications

- Gas Chromatography
- Process Analyzers
- Laser Gas Systems
- High Purity Gas Systems
- Non-Corrosive Gases
- Corrosive Gases

## ORDERING: Model Number System

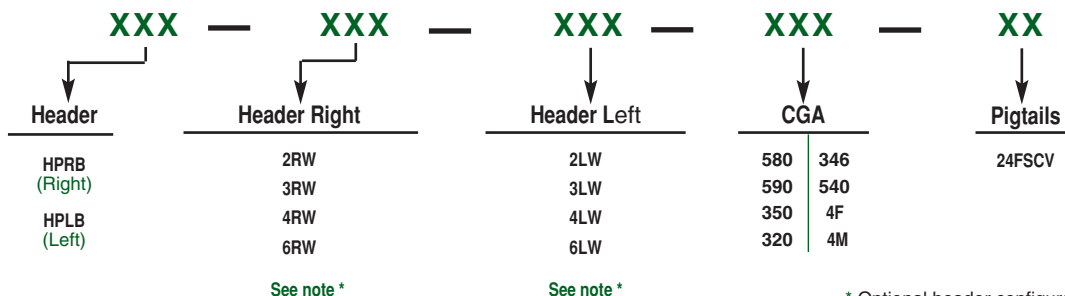

\* Optional header configurations are available.



## HPRS & HPLS

### Stainless Steel Headers

Victor stainless steel headers are designed for corrosive and non-corrosive gas applications where cylinders are needed to supply critical processes.

The materials of construction will not off-gas and contaminate the gas stream. The design is highly resistant to inboard diffusion of atmospheric conditions. Victor DRK diffusion resistant shut off valves. Flexible braided stainless steel pigtails, lined with stainless steel are standard.

### HPRS & HPLS Features

- Tig welded construction for maximum leak protection.
- 7/8" O.D. stainless steel pipe with forged tees.
- DRK packless diaphragm shut off valves.
- Flexible braided stainless steel pigtails, lined with stainless steel, with check valves.
- Rated for hydrogen and helium service.
- Easily connected to PDS and VHP.

### Materials of Construction

Pipe .....	303 Stainless Steel
Tees .....	304 Forged Stainless Steel
Valves .....	Packless Diaphragm
Pigtails .....	Stainless Steel Braided, Stainless Steel Lined

### HPRS & HPLS Specifications

Maximum inlet pressure .....3000 psig  
 Inlet connections are standard CGAs.  
 Outlet connections are standard CGAs.

### Typical Applications

- Gas Chromatography
- Process Analyzers
- Laser Gas Systems
- High Purity Gas Systems
- Non-Corrosive Gases
- Corrosive Gases

### ORDERING: Model Number System

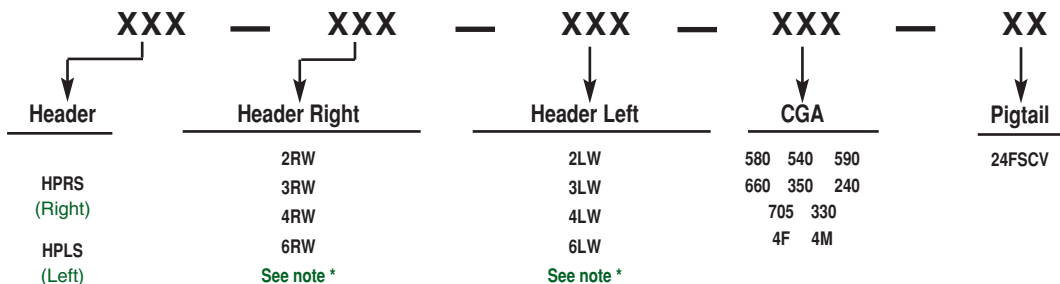

\* Optional header configurations are available.



## Pressure Switches

These pressure switches are designed to activate remote alarm systems on Victor manifold systems. Once your minimum pressure is set, the pressure switch will activate your remote alarm upon depletion. These are explosion proof models in 15 amp 125 / 250 / 480 VAC resistive design. Switches can be wired “normally opened” or “normally closed.”



CSA Listed  
FM Approved

Part No.	Pressure Range (psig)	Maximum Inlet (psig)	Diaphragm Materials	Classification	Switch Output	Electrical Connections	Pressure Connections
1118-0068	1-20	500	316 SS	Explosion proof	SPDT	3/4" NPT(F)	1/4"NPT(F)
1118-0069	2-50	500	316 SS	Explosion proof	SPDT	3/4" NPT(F)	1/4"NPT(F)
1118-0070	125-3000	10,000	303 SS	Cleaned for oxygen	SPDT	1/2" NPT(F)	1/4"NPT(F)
1118-0071	30-575*	2500	Viton	Cleaned for oxygen	SPDT	1/2" NPT(F)	1/4"NPT(M)
1118-0072	0-300	350	316SS	Cleaned for oxygen	SPDT	7/8"	1/4"NPT(F)
1118-0074	50-1000	6000	316 SS	NEMA 4;7;9; IPGG	SPDT	3/4" NPT(F)	1/2"NPT(F)
1118-0075	250-3500	6000	316 SS	NEMA 4;7;9; IPGG	SPDT	3/4" NPT(F)	1/2"NPT(F)

\* Factory set at 183 psig

## Remote Alarms

Victor Alarm Systems are designed to provide a warning of service interruption when used on manifolds. Used in conjunction with a pressure switch, the Victor Alarm System will provide both visual or audio/visual warning of cylinder depletion. The Victor Alarm System is for use with one or two gas manifold systems. Once activated, a visual only alarm will change from a “green” indicator for normal operation to a “red” indicator for depleted cylinders. Once the system is repressurized, the indicator lights will return to the normal “green” position. For systems with the audio/visual feature and audible buzzer (alarm) is rated at 90 DB @ 2ft. Alarm will ring and signal that the primary bank of cylinders is depleted. A reset button conveniently located on the front of the unit will deactivate the buzzer. The "red" light will remain on until the exhausted bank has been replaced. Ideal for Industry, Medical and Specialty Gas use. Easy to wire and helps prevent downtime.



### Design & Construction

- Transformer (125 VAC X 15 VDC) with 6 foot cord included
- Panels may be flush or back mounted
- 125 VAC/15 VDC
- Durable plastic case
- High intensity LED's

### Dimensions

- Visual: 5"Hx3"Lx2"D
- Audio/Visual: 6"Hx3"Wx2"D
- Two Gas: 6"Hx6"Wx2"D

Part no.	Model No.	Type	# of Gases
0265-0030	MA24-1V	VISUAL	1
0265-0031	MA24-1AV	AUDIO/VISUAL	1
0265-0032	MA24-2AV	AUDIO/VISUAL	2
0265-0033	MA115-1V	VISUAL	1
0265-0034	MA115-1AV	AUDIO/VISUAL	1
0265-0035	MA115-2AV	AUDIO/VISUAL	2



The Victor Bypass Valve is designed to allow shut-down of primary gas supply without interruption of gas service. These 1/2" and 3/4" bypass assemblies permit the user to shut off the primary supply and access a back-up or temporary gas source. This can be used to perform routine manifold maintenance and repair.

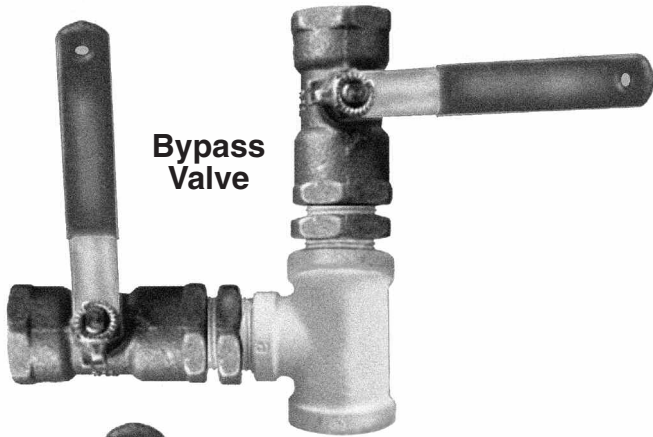

**Bypass Valve**

## Bypass Valves

### Design and Construction

- Ball Valves (2)
- 1/2" NPT and 3/4" NPT Models
- Brass bar stock tees and connections

### Performance Specifications

- Maximum pressure: 400 psig

Bypass Valve Ordering Information	
Part No.	Description
1115-0000	1/2" Bypass Valve
1115-0001	3/4" Bypass Valve

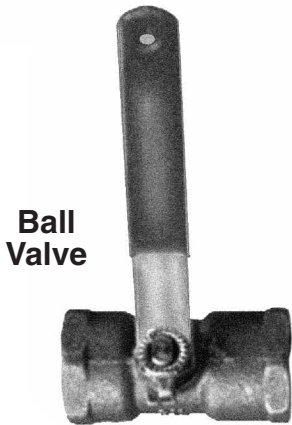

**Ball Valve**

### Ball Valve Features

- Forged brass body
- Teflon seat
- Chrome plated ball
- Teflon seals
- Steel handle
- 400 psig rating
- Clean for Oxygen service

## Ball Valves

Ball Valve Ordering Information	
Part No.	Description
0660-0032	1/2" Ball Valve
0660-0042	3/4" Ball Valve

Manifold Accessories

## Hydraulic Flash Arrestors

Required on manifolds with two or more Fuel Gas Cylinders. These units provide flashback protection at the source of the gas. These systems are designed to provide protection via the use of ethylene-glycol in the unit. Ethylene Glycol is provided with all units.

Included in each unit is a pressure relief valve which provides additional protection to the system in the event of over-pressurization. Maximum flow is 1000 SCFH for the FB-2A and 300 SCFH for the FB-1A. Hydraulic Arrestors are FM approved.



Part No.	Model no.	Gas Service
1116-0038	FB-2A	Acetylene
1116-0039	FB-2LPG	LPG
1116-0037	FB-S (Stand only)(1000)	All Gases
1116-0033	Pigtail-Dry Type	AC
1116-0045	FB-1A	Acetylene
1116-0046	FB-1LPG	LPG
1116-0044	Stand (only)(300)	All Gases

## Wall Brackets Floor Stands, & Manifolds Stands

Every Victor system comes equipped with mounting brackets so the system can be permanently mounted to a wall. In the event that wall mounting is not feasible, all Victor systems can be Floor Mounted via our Floor Stand. This stand fits all Victor Manifolds and one is recommended for every 4 cylinders. Just attach the mounting brackets included with the floor stand and you are ready to go.

Chaining or bracketing cylinders is required. Therefore, Victor provides the following wall mount brackets or stands for use with your manifold system. Available in single or double cylinder designs, chain included.

**Double**



**Single**



Part No.	Mounts	No. of Cylinders	Types of Gas	Dimensions
1421-0045	Wall Mount	Single Cylinder	O <sub>2</sub> & Inerts	9" wide
1421-0046	Wall Mount	Single Cylinder	Acetylene & Fuel Gas	13" wide
1421-0047	Wall Mount	Two Cylinder	O <sub>2</sub> & Inerts	9" wide
1421-0048	Wall Mount	Two Cylinder	Acetylene & Fuel Gas	13" wide
1106-0100	Stand	Manifold Stand	Oxygen, Inerts, Acetylene & Fuel Gas	60-1/2" Tall (5'1/2")
1106-0016	Wall Mount	Manifold Brackets (1)		

## Gas Service Labels & Placards

Safety in a manifold environment is Victor's number one concern. As a result we have made available the same labels that we use on our systems for use with your manifold and piping system.

These labels allow all piping to be labeled with the gas service contained in the pipe or system.

Part No.	Description
1415-0356	Oxygen
1415-0363	Argon
1415-0369	HELIUM
1415-0362	Nitrogen
1415-0364	Carbon Dioxide
1415-0368	Breathing Air
1415-0361	Compressed Air
1415-0365	Nitrous Oxide
1415-0373	Acetylene

Part No.	Description
1415-0357	Mapp
1415-0358	Propane
1415-0366	Propylene Based Gas
1415-0359	Natural Gas
1415-0367	LP Gas (LPG)
1415-0360	Hydrogen
1415-0371	Argon-CO <sub>2</sub>
1415-0372	Helium-Argon-CO <sub>2</sub>
1415-0370	"Direction Arrow"

## Pigtails

Replacement pigtails for Victor manifolds or applications requiring pigtails. Rigid copper and stainless steel braided flexible models available. Dry Flash Arrestor included.

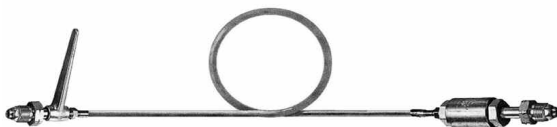

**Rigid**

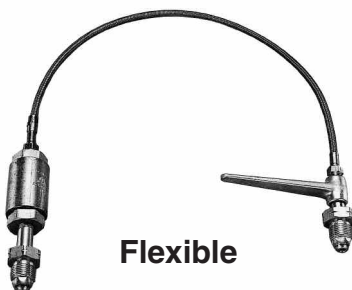

**Flexible**

Part No.	CGA & Gas Service	Length	Type	Check Valve
1123-0020	320 CO <sub>2</sub>	24"	Flexible	Yes
1123-0078	300 Acetylene	24"	Flexible	Yes + FA
1123-0017	320 Carbon Dioxide	24"	Flexible	No
1123-0594	326 Nitrous Oxide	24"	Rigid	Yes
1123-0596	346 Breathing Air	24"	Flexible	Yes
1123-0016	350 Hydrogen Methane	24"	Rigid	No
1123-0597	350 Hydrogen Methane	24"	Rigid	Yes
1123-0009	510 Acetylene	24"	Flexible	Yes + FA
1123-0008	510 Acetylene, LP Gas	24"	Flexible	Yes
1123-0503	540 Oxygen	24"	Rigid	No
1123-0504	540 Oxygen	24"	Rigid	Yes
1123-0505	540 Oxygen	36"	Rigid	Yes
1123-0606	540 Oxygen	24"	Flexible	Yes
1123-0609	540 Oxygen	36"	Flexible	Yes
1123-0600	540 Oxygen	48"	Flexible	Yes
1123-0601	540 x 1/4"NPT(M) Oxygen	120"	Flexible	Yes
1123-0013	580 Inert Gas	24"	Flexible	No
1123-0599	580 Inert Gas	24"	Flexible	Yes
1123-0506	580 Inert Gas	48"	Flexible	Yes
1123-0507	580 Helium	24"	Rigid	Yes
1123-0014	590 Air	24"	Flexible	No

FA = Dry Flash Arrestor (Included)

Manifold Accessories

Globe Valve

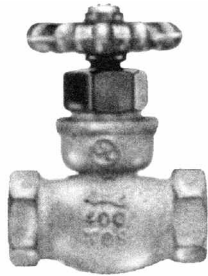

Master Valve

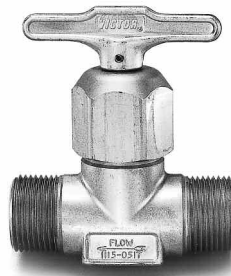

Module Valve



**Valves**

Part No.	Description	Inlet	Outlet
1113-0003	Globe Valve	3/4" NPT(F)	3/4" NPT(F)
1114-0000	Module Valve - Oxygen	CGA 540	1/2"NPT(M)
1114-0010	Station Valve - Oxygen with cap chain, check valve	1/2" NPT(M)	7/8"-14 RH
1115-0517	Master Valve	1"-11-1/2" NPS RH(M)	1"-11-1/2" NPS RH(M)
1115-0515	Master Valve	1/2 NPT(F)	1/2 NPT(F)
1190-0000	Master Valve - Repair Kit		

Manifold Accessories

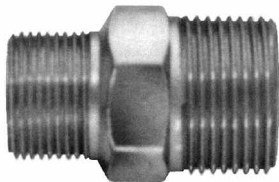

Adaptor

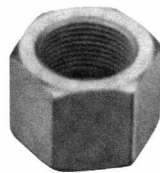

Nut

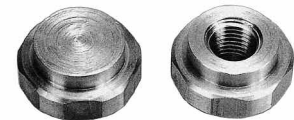

End Plug

End Plug with 1/4" NPT(F) Port

**Union Fittings & Adaptors**

Part No.	Type	Description
0996-0018	Adaptor	3/4" NPT(M) X 1"-11-1/2" NPS RH *Use with 1113-0003
0996-0014	Adaptor	1/2" NPT(M) X 1"-11-1/2" NPS RH
0996-0020	Adaptor	1/4" NPT(M) X 1"-11-1/2" NPS RH
0997-0006	Adaptor	3/4" NPT(M) X 1"-11-1/2" NPS LH *Use with 1113-0003
0997-0007	Adaptor	1/2" NPT(M) X 1"-11-1/2" NPS LH
0997-0020	Adaptor	1/4" NPT(M) X 1"-11-1/2" NPS LH
0996-0004	Nut	1"-11-1/2" NPS RH (M) 996
0997-0004	Nut	1"-11-1/2" NPS LH (M) 997
1108-0592	End Plug	with 1/4" NPT(F) Port for Pressure Switch
0996-0005	Swivel	1/2" NPT(M) X 996/997
0996-0022	Swivel	1/4" NPT(M) X 996
0996-0031	Swivel	1/4" NPT(M) X 997 (*special; 125 orifice for Hydrogen)
0996-0012	Bushing	1"-11-1/2" NTS(RM) x 1"-11-1/2" NTS(RM)



Nut & Plug

## Station Regulators - Not for Cylinder Use

See page 10 & 11 for station drop data

Regulator	Part No.	Model #	Inlet PSIG	Delivery (PSIG)	Gas Service	Connections	
						Inlet	Outlet
Light - Medium Flow Station Regulator • Side Inlet • Bottom Inlet	0781-1253	S250B-024	200	2-40	Oxygen	7/8"-14 RH (F)	9/16"-18 RH (M)
	0781-1254	S250C-024	200	4-80		7/8"-14 RH (F)	9/16"-18 RH (M)
	0781-1255	S250D-024	200	5-125		7/8"-14 RH (F)	9/16"-18 RH (M)
	0781-1246	S250B-034	200	2-40	Inert-CO <sub>2</sub>	7/8"-14 RH (M)	5/8"-18 (F)
	0781-1247	S250C-034	200	4-80		7/8"-14 RH (M)	5/8"-18 (F)
	0781-1248	S250D-034	200	5-125		7/8"-14 RH (M)	5/8"-18 (F)
	0781-1244	SFG250-034	200	10-40 SCFH	Flow Gauge Reg.	7/8"-14 RH (M)	5/8"-18 (F)
	0781-1245	S2570-034	200	5-70 SCFH	Station W/ Flow Gauge	7/8"-14 RH (M)	5/8"-18 (F)
	0781-1256	S260A-025	200	2-15	Acetylene	7/8"-14 LH (M)	9/16"-18 LH (M)
	0781-1257	S261C-025	200	4-80	Hydrogen& LP Gas	7/8"-14 RH (M)	9/16"-18 LH (M)
0781-1258	S261D-025	200	5-125	7/8"-14 RH (M)		9/16"-18 LH (M)	
Medium Heavy Flow Station Regulator • Rear Inlet • Bottom Inlet	0781-2458	S350BR-024	200	2-40	Oxygen	7/8"-14 RH (F)	9/16"-18 RH (M)
	0781-2459	S350CR-024	200	4-80		7/8"-14 RH (F)	9/16"-18 RH (M)
	0781-2460	S350DR-024	200	5-125		7/8"-14 RH (F)	9/16"-18 RH (M)
	0781-2463	S350BR-034	200	2-40	Inert-CO <sub>2</sub>	7/8"-14 RH (M)	5/8"-18 (F)
	0781-2464	S350CR-034	200	4-80		7/8"-14 RH (M)	5/8"-18 (F)
	0781-2465	S350DR-034	200	5-125		7/8"-14 RH (M)	5/8"-18 (F)
	0781-2472	S360AR-025	200	2-15	Acetylene	7/8"-14 LH (F)	9/16"-18 LH (M)
0781-2486	S361DR-025	200	5-125	Hydrogen& LP Gas	7/8"-14 LH (F)	9/16"-18 LH (M)	
Medium Heavy Flow Station Regulator • Side Inlet • Bottom Inlet	0781-2490	S350A-024	200	2-15	Oxygen	7/8"-14 RH (F)	9/16"-18 RH (M)
	0781-2491	S350B-024	200	2-40		7/8"-14 RH (F)	9/16"-18 RH (M)
	0781-2492	S350C-024	200	4-80		7/8"-14 RH (F)	9/16"-18 RH (M)
	0781-2493	S350D-024	200	5-125		7/8"-14 RH (F)	9/16"-18 RH (M)
	0781-2495	S350B-034	200	2-40	Inert-CO <sub>2</sub>	7/8"-14 RH (M)	5/8"-18 (F)
	0781-2496	S350C-034	200	4-80		7/8"-14 RH (M)	5/8"-18 (F)
	0781-2497	S350D-034	200	5-125		7/8"-14 RH (M)	5/8"-18 (F)
	0781-2500	S360A-025	200	2-15	Acetylene	7/8"-14 LH (F)	9/16"-18 LH (M)
	0781-2505	S361C-025	200	4-80	Hydrogen& LP Gas	7/8"-14 LH (F)	9/16"-18 LH (M)
	0781-2506	S361D-025	200	5-125		7/8"-14 LH (F)	9/16"-18 LH (M)
High Flow Station Regulator • Side Inlet • Bottom Inlet	0780-1268	S700B-996	350	2-40	Oxygen	1"-11-1/2 NPS (F)	7/8"-14 RH (M)
	0780-1273	S700D-996	350	5-125	Inert-CO <sub>2</sub>	1"-11-1/2 NPS (F)	7/8"-14 RH (M)
	0780-1274	S710A-997	350	2-15	Acetylene	1"-11-1/2 NPS (F)	7/8"-14 LH (M)
	0780-1275	S711C-997	350	4-80	Hydrogen& LP Gas	1"-11-1/2 NPS (F)	7/8"-14 RH (M)

### CGA Conversions

**CGA 024** = 7/8" - 14 RH(F) Oxygen  
**CGA 025** = 7/8" - 14 LH(F) Acetylene & Fuel Gases  
**CGA 034** = 7/8" - 14 RH(M) Inert Gases  
**B Size** = 9/16" - 18 RH Oxygen  
**B Size** = 9/16" - 18 LH Acetylene & Fuel Gases  
**B Size** = 5/8" - 18 RH Inert Gas



## Line Regulators - Not for Cylinder Use

REGULATOR	PART#	MODEL #	MAX INLET	DELIVERY PSIG	GAS SERVICE	CONNECTIONS	
						INLET	OUTLET
Light Flow Line Regulator	0781-1249	L250D-250	350	5-125	Air, Inert O <sub>2</sub> , CO <sub>2</sub> , N <sub>2</sub> O	1/4" NPT (F)	1/4" NPT (F)
	0871-1285	Panel Mount -Same as L250D-250					
	0781-1296	L261C-250	350	4-80	Hydrogen & LP Gas	1/4" NPT (F)	1/4" NPT (F)
	0781-1286	Panel Mount					
	0781-1260	L260A-250	350	2-15	Acetylene	1/2" NPT (F)	1/2" NPT (F)
	0781-1281	Panel Mount -Same as L260A-250					
Medium Flow Line Regulator	0781-2455	L350D-250	350	5-125	Air, Inert O <sub>2</sub> , CO <sub>2</sub> , N <sub>2</sub> O	1/4" NPT (F)	1/4" NPT (F)
	0781-2480	L361C-250	350	4-80	Hydrogen & LP Gas	1/4" NPT (F)	1/4" NPT (F)
	0781-2481	L361D-250	350	5-125		1/4" NPT (F)	1/4" NPT (F)
	0781-2467	L360A-250	350	2-15	Acetylene	1/4" NPT (F)	1/4" NPT (F)
Heavy Flow Line Regulator	0780-1229	L700C-500	350	4-80	Air, Inert O <sub>2</sub> , CO <sub>2</sub> , N <sub>2</sub> O	1/2" NPT (F)	1/2" NPT (F)
	0780-1207	L700D-500	350	5-125		1/2" NPT (F)	1/2" NPT (F)
	0780-1236	Panel Mount -Same as L700D-500					
	0780-1231	L700E-500	350	10-200		1/2" NPT (F)	1/2" NPT (F)
	0780-1199	L711D-500	350	5-125	Hydrogen & LP Gas	1/2" NPT (F)	1/2" NPT (F)
	0780-1233	L710A-500	350	2-15	Acetylene	1/2" NPT (F)	1/2" NPT (F)
	0780-1201	L710A-750	350	2-15		3/4" NPT(F)	3/4" NPT (F)
	0780-1220	L700C-750	350	4-80	Air, Inert O <sub>2</sub> , CO <sub>2</sub> , N <sub>2</sub> O	3/4" NPT (F)	3/4" NPT (F)
	0780-1209	L700D-750	350	5-125			
	0780-1222	L700E-750	350	10-200			

## Flowmeters - Not for Cylinder Use

Victor Flowmeters are precision, gas-flow measuring instruments designed for use in distribution systems, laboratories, MIG/TIG welding and a variety of other applications. Flowtubes and outer covers are made of impact resistant Lexan for maximum durability and service life.



### Units with Single Gas Calibration

Part No.	Model #	Flow Range	Inlet Fitting	Outlet Fitting	Flowtube Only
1000-0253	FM133	5-40 SCFH Hydrogen	9/16"-18 LH F	9/16"-18 LH M	1015-0070
1000-0271	FM153	5-40 SCFH Hydrogen	1/4" NPT M	9/16" LH M	1015-0070
1000-0254	FM132	15-75 SCFH Hydrogen	9/16"-18 LH F	9/16"-18 LH M	1015-0071
1000-0270	FM152	15-75 SCFH Hydrogen	1/4" NPT M	9/16"-18 LH M	1015-0071
1000-0264	FM200	30-100 SCFH CO <sub>2</sub>	1/4" NPT M	5/8"-18 RH F	1015-0066

### Units with Two Gas Calibration

Part No.	Model #	Flow Range	Inlet Fitting	Outlet Fitting	Flowtube Only
1000-0251	FM130	10-60 SCFH Air 10-60 SCFH Nitrogen	9/16"-18 RH F	5/8"-18 RH F	1015-0060
1000-0268	FM150	10-60 SCFH Air 0-60 SCFH Nitrogen	1/4" NPT M	5/8"-18 RH F	1015-0060
1000-0255	FM135	4-18 SCFH Argon 10-50 SCFH Helium	9/16"-18 RH F	5/8"-18 RH F	1015-0063
1000-0256	FM145	4-18 SCFH Argon 0-50 SCFH Helium	5/8"-18 RH M	5/8"-18 RH F	1015-0063
1000-0257	FM155	4-18 SCFH Argon 10-50 SCFH Helium	1/4" NPT M	5/8"-18 RH F	1015-0063
1000-0261	FM137	15-65 SCFH Argon 40-200 SCFH Helium	9/16"-18 RH F	5/8"-18 RH F	1015-0064
1000-0262	FM147	15-65 SCFH Argon 40-200 SCFH Helium	5/8"-18 RH M	5/8"-18 RH F	1015-0064
1000-0263	FM157	15-65 SCFH Argon 40-200 SCFH Helium	1/4" NPT M	5/8"-18 RH F	1015-0064

### Units with Three Gas Calibration

Part No.	Model #	Flow Range	Inlet Fitting	Outlet Fitting	Flowtube Only
1000-0258	FM370	5-40 SCFH CO <sub>2</sub> 5-50 SCFH Argon 20-150 SCFH Helium	9/16"-18 RH F	5/8"-18 RH F	1015-0057
1000-0259	FM371	5-40 SCFH CO <sub>2</sub> 5-50 SCFH Argon 20-150 SCFH Helium	5/8"-18 RH M	5/8"-18 RH F	1015-0057
1000-0182	FM372	5-50 SCFH ARGON 5-40 SCFH CO <sub>2</sub> 20-150 SCFH Helium	1/4" NPT M	5/8"-18 RH F	1015-0057

**NOTE:** All Victor flowmeters are back pressure compensated to ensure accurate readings at all times, even if line restrictions are present. All flowmeters are calibrated to operate at 25 PSIG inlet pressure except the FM 200 which is calibrated to operate at 80 PSIG.

# Manifold Regulator Chart

Description/Usage	Part no.	Model #	Delivery (PSIG)	Gas Service	Connections
<b>SR 450 Series</b> Heavy Duty, Single Stage Used in: DUAL, SPLX, SSIN, SAM, LIQ (HP)	0781-0622	SR452MA-997	A 2-15	Hydrogen	Inlet 1"-11 1/2" NPS(M) Outlet 1"-11 1/2" NPS(F)
	0781-0617	SR460MA-997	A 2-15	Acetylene	
	0781-0618	SR461MB-997	B 2-40	LP Gas	
	0781-0611	SR450MD-996	D 5-125	O <sub>2</sub> & Inerts	
	0781-0613	SR452MD-997	D 5-125	Hydrogen	
	0781-0615	SR453MD-996	D 5-125	N <sub>2</sub> O, CO <sub>2</sub>	
	0781-0619	SR461MD-997	D 5-125	LP Gas	
<b>SR 700 Series</b> High Flow, Single Stage Used in: SPLX, SSIN	0780-0806	SR710MA-997	A 2-15	Acetylene	Inlet 1"-11 1/2" NPS(M) Outlet 1"-11 1/2" NPS(F)
	0780-0807	SR711MB-997	B 2-40	LP Gas	
	0780-0797	SR700MD-996	D 5-125	O <sub>2</sub> & Inerts	
	0780-0798	SR700ME-996	E 10-200	O <sub>2</sub> & Inerts	
	0780-0803	SR702ME-997	E 10-200	Hydrogen	
	0780-0805	SR703ME-996	E 10-200	N <sub>2</sub> O,CO <sub>2</sub>	
<b>SR 4 Series</b> High Delivery, Single Stage Used in: SPLX	0781-1457	SR4MF-996	F 50-750	All Except	Inlet 1"-11 1/2" NPS(M) Outlet 1"-11 1/2" NPS(F)
	0781-1437	SR4MG-996	G 100-1500	Hydrogen	
	0781-1458	SR4MJ-996	J 200-3000	Methane	
	0781-1456	SR4MJ-997	J 200-3000		
	0781-1454	SR4TJ-996	J 200-3000	O <sub>2</sub> Transfill	
<b>BSL-700 Series</b> Liquid Cylinder Regulator	0780-1200	BSL700-500	E 10-200	CO <sub>2</sub> & Inerts	Inlet 1/2" NPT(F) Outlet 1/2" NPT(F)
<b>LC-700 Series</b> Liquid Cylinder Regulator Used in: LIQ	0780-1198	LC700-996	E 10-200	O <sub>2</sub> & Inerts	Inlet 1"-11 1/2" NPS(M) Outlet 1/2"NPT(F)
<b>VTS 450 Series</b> Two Stage	0781-3961	VTS452MD-997	D 5-125	Hydrogen	Inlet 1"-11 1/2" NPS(M) Outlet 1-11 1/2" NPS(F)
	0781-3962	VTS452ME-997	E10-200	Hydrogen	
<b>VTS 700 Series</b> Two Stage, High Flow UP TO 7000 SCFH	0780-1006	VTS710MA-997	A 2-15	Acetylene	Inlet 1"-11 1/2" NPS(M) Outlet 1/2" NPT(F)
	0780-1007	VTS711MB-977	B 2-40	LP Gas	
	0780-0997	VTS700MD-996	D 5-125	O <sub>2</sub> & Inerts	
	0780-1004	VTS703MD-996	D 5-125	CO <sub>2</sub>	
	0780-0998	VTS700ME-996	E10-200	O <sub>2</sub> & Inerts	
	0780-1005	VTS703ME-996	E 10-200	CO <sub>2</sub>	

Special regulators can be requested for your application should the standard be inappropriate for your application. Please contact **Customer Service at 1-800-569-0547** for more information.

## Manifold Regulator Flow Data

The following information is provided to show manifold delivery capability (SCFH) with **MINIMUM** (200 PSIG) cylinder pressure. Tests were conducted using air at 70 degrees Fahrenheit and with no flow restrictions.

### MA Models A Delivery Range

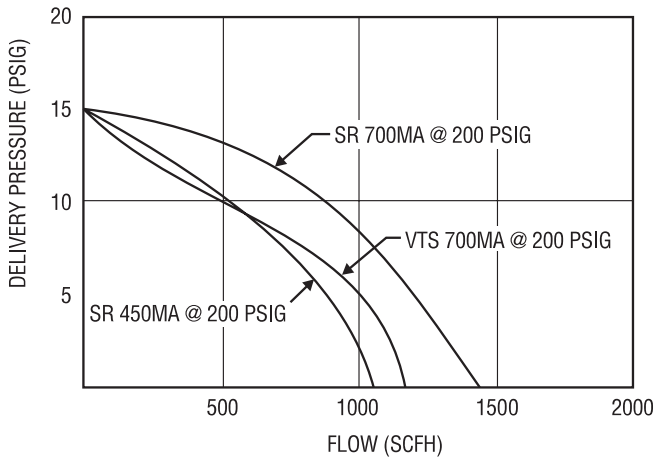

### MB Models B Delivery Range

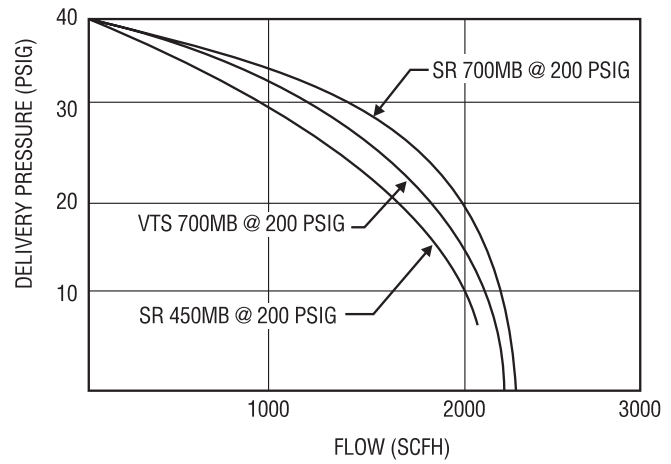

### MD Models D Delivery Range

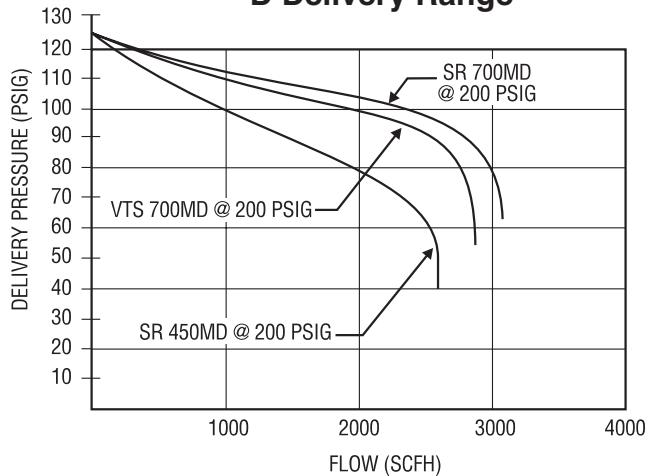

### ME Models E Delivery Range

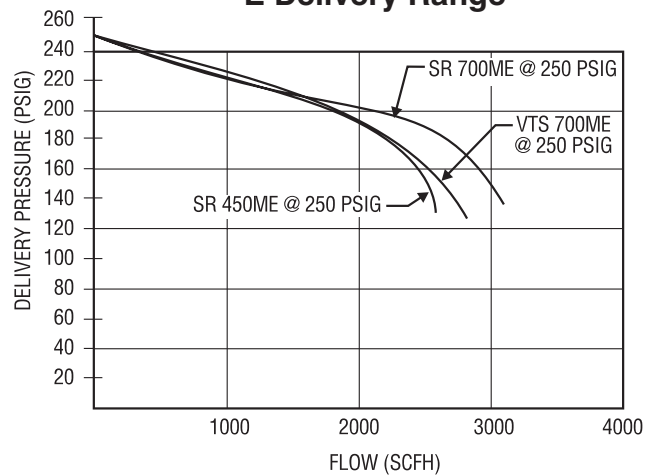

**Victor single stage regulators...** are recommended for applications where slight delivery pressure changes due to decreasing cylinder pressures would not affect flow/pressure requirements.



## Regulator Performance Data

### How to read the Flow Data Charts on the following pages:

The regulator flow data is provided to assist in determining the proper regulator for the required application. The data is given for reference purpose only. If additional information is necessary, contact your local distributor or call Customer Service (U.S.) 1-800-569-0547.

The regulator flow data was established by connecting a valve to the regulator outlet. The valve was opened and the flow rates measured. The amount of pressure drop is shown on the curves (p. 22) as the flow increases.

<b>Pressure Range</b>	<b>Static Pressure</b>
A .....	15 PSIG
B .....	40 PSIG
C .....	80 PSIG
D .....	25 PSIG
E .....	200 PSIG
F .....	750 PSIG
G .....	1500 PSIG
J .....	3000 PSIG
K .....	4500 PSIG

With an inlet pressure of 200 PSIG and an initial setting of 125 PSIG, the regulator will flow 1000 SCFH with a pressure drop to 98 PSIG. At 2000 SCFH flow, the pressure will drop to 78 PSIG. If a delivery pressure other than the ones shown on the flow charts is required, use an average curve rate between the upper and lower pressures shown.

### Cylinder Pressure Rise

Single Stage regulators have a rise (increase) in delivery pressure as the cylinder pressure decreases. Listed below is the amount of pressure rise (increase) per 100 PSIG decrease in cylinder (inlet) pressure.

SR 4 Series .....	G Range 2.4
SR 4 Series .....	J Range 4.8
SR 450 Series .....	0.6
SR 700 Series .....	1.2

The change in delivery pressure of a Two Stage regulator from full to empty cylinder (inlet) pressure is negligible.

## For Conversion to Other Gases

All flow capacity information is given in SCFH of free air (1.00). For conversion to other gases multiply the air flow by the correction factor listed below.

Acetylene .....	1.05	Mapp <sup>®</sup> .....	.82
Argon .....	.85	Natural Gas .....	1.28
Carbon Dioxide .....	.81	Nitrogen .....	1.02
Helium .....	2.69	Oxygen .....	.95
Hydrogen .....	3.79	Propane .....	.80

**For Manifold questions call**  
**1-800-569-0547**

## How Many Cylinders Do I Need?

### High Pressure

A typical large high pressure cylinder is 220 CF and actually contains 250 CF of gas due to a 10% overfill allowance. Using the formula below, the required number of cylinders for your application can be determined.

#### Example of Argon Mix Manifold System at a MIG Welding Shop:

(250 CF/Cylinder) less 20 CF left in Cylinder due to auto changeover leaves 230 CF/Cylinder. 250 CF if it's a manual changeover system.

(28 CFH/Station) x 6.5 Hours/Day x 50% Duty Cycle = 91.0 CF/Day/Station

91.0 CF/Day/Station x 8 Welding Stations = 728 CF/Day

$$\frac{728 \text{ CF/Day}}{230 \text{ CF/Cylinder}} = 3.16 \text{ Cylinders/Day}$$

$$\frac{12 \text{ Cyls. per Header}}{3.16 \text{ Cylinders/Day}} = 3.8 \text{ Days per Header} \times 2 \text{ Headers} = \text{Maximum 7.6 Days between deliveries}$$

Minimum Gas supply of 1 day required. Thus, in order to get gas delivery once a week (ie. every Wednesday) we need 24 cylinders delivered every seven days in order to have continuous, uninterrupted service with an automatic changeover manifold.

Formula on page 4 under "Determining the Right Manifold for your Application."

## How To Select The Correct Number of Acetylene Cylinders

To determine the number of Acetylene cylinders required for proper manifold operation, follow the guidelines below:

1. The number of cylinders in the manifold is determined by the volume of gas in cubic feet per hour required. Determine the cubic feet per hour required for the largest tip used and multiply that by the number of torches, or stations, in operation at the same time. This will give you the total volume of each gas required per hour.
2. The manifold should have enough cylinders to provide a minimum of one day's requirements.
3. Maximum Acetylene withdrawal for continuous operation is 1/7\* of each cylinder per hour. This chart is at a continuous withdrawal rate @ 70°F and 250 PSIG.

\* CGA Pamphlet G-1

CFH Acetylene withdrawal per hour required	# of 300 CF cylinders per header continuous service
40	1
80	2
120	3
160	4
200	5
240	6
280	7
320	8
360	9
400	10
500	12
600	14
700	17
800	20

@ 70°F and 250 PSIG

## Manifold System Layouts

Whether it's a standard or special configuration, Victor has the system for you. All we need to know is the requirements (ie. sizes, shapes, etc.) and we can build it for you. It is that simple. The following are examples of the most common configuration requirements.

### Standard

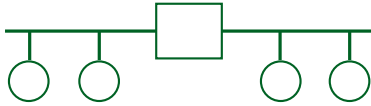

Wall Mount or Floor Stand Option  
10" Centers O<sub>2</sub> & Inerts  
13" Centers for Fuel Gases

### "L" Shaped

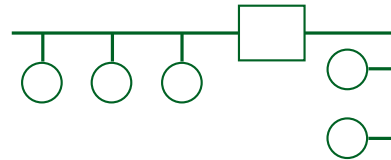

Wall Mount or Floor Stand Option  
10" Centers O<sub>2</sub> & Inerts  
13" Centers for Fuel Gases

### "U" Shaped

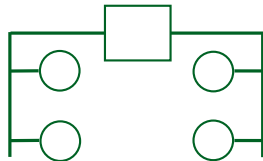

Wall Mount or Floor Stand Option  
10" Centers O<sub>2</sub> & Inerts  
13" Centers for Fuel Gases

### Crossover-Stand Mount

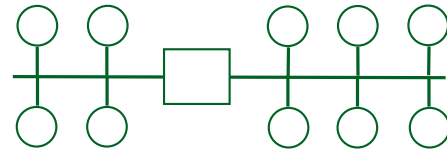

Floor Stand Option  
10" Centers O<sub>2</sub> & Inerts  
13" Centers for Fuel Gases

### Staggered or Short

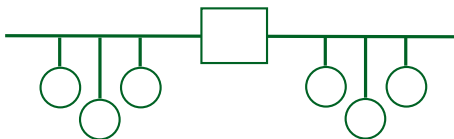

Wall Mount or Floor Stand Option  
10" Centers O<sub>2</sub> & Inerts  
13" Centers for Fuel Gases

### Long

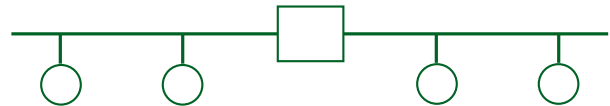

Wall Mount or Floor Stand Option  
10" Centers O<sub>2</sub> & Inerts  
13" Centers for Fuel Gases

**NOTE:** Special configuration manifolds are built to your specification. Victor will not build a unit unless details of required dimensions are provided by the customer. Should you require assistance please contact **Victor Customer Service 1-800-569-0547**.

The Victor Equipment Company would like to make the following recommendations when piping your shop. This obviously is a crucial element to the manifold system; listed below are some guidelines for choosing the right size pipe. Consult your contractor, plus your local fire and building codes when making any final decision. The following charts provide a guideline for selecting the correct pipe size for your system. Pressure drop information is on the next page.

### Oxygen Distributing Systems

#### Pipe Sizes

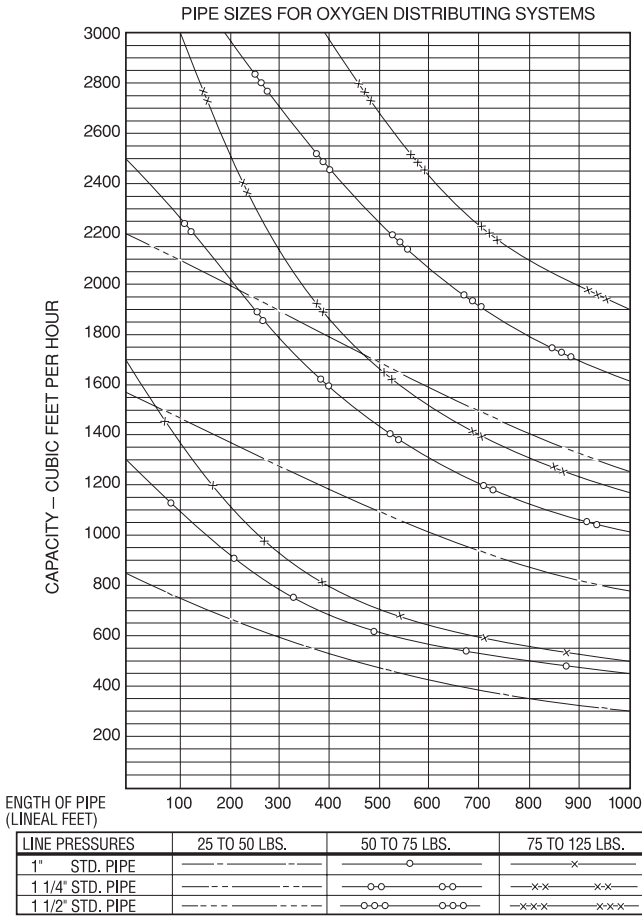

### Acetylene Distributing Systems

#### Pipe Sizes (15 Pounds Pressure)

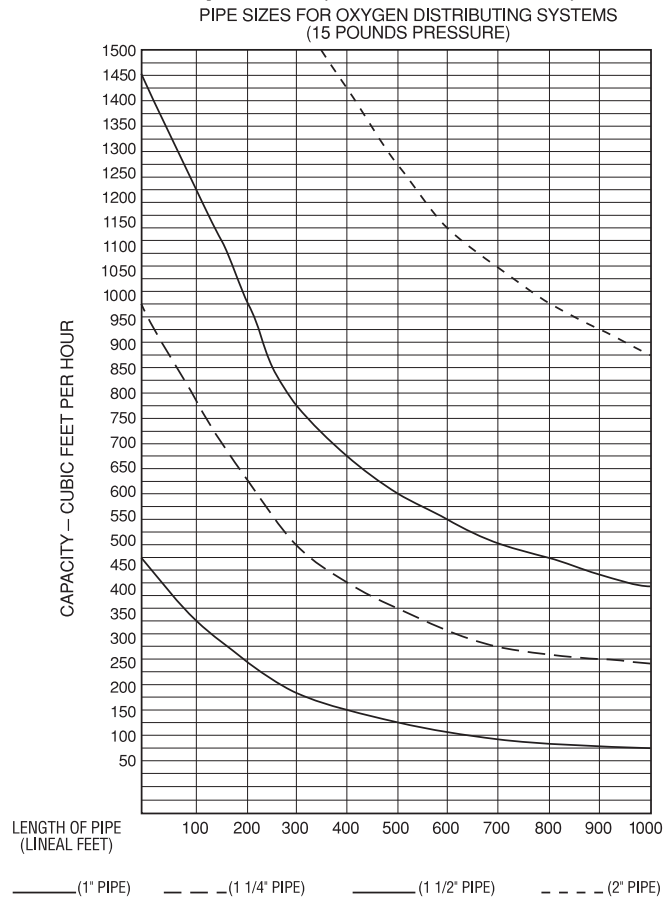

Consult your Contractor or Local Fire and Building Codes for more information pertinent to your particular locale.

### Friction Loss of Air in Pipe Fittings

(Expressed in Terms of Feet of Straight Pipe)

Nominal Pipe sizes Inches	Schedule No.	Globe Valve	Gate Valve	90° Standard Elbow	Standard Tee	
					Run of Tee	Side Outlet
1/2"	40	17.6	.7	1.6	1.0	3.1
3/4"	40	23.3	.9	2.1	1.4	4.1
1"	40	29.7	1.1	2.6	1.7	5.2
1-1/2"	40	45.5	1.7	4.0	2.7	8.1
2"	40	59	2.2	5.2	3.4	10.3



## Piping Systems Gas Flow and Pressure Data

The performance of gas apparatus supplied by manifold and piping systems is largely dependent upon pressure stability and adequate gas flow. The following charts are provided to assist in determining the minimum size requirements for piping and hose needed to provide sufficient gas flow without excessive pressure drop.

**Note:** Values may vary  $\pm$  10% depending on operating conditions.

### Pressure Drop in Pounds for Each 100 Feet of Straight Pipe

Nominal Pipe Size	SCFH Free Air	Line Pressure - PSIG							
		10	15	30	50	100	150	200	250
1/2" Schedule 40	500		1.50	1.00	.70	.40	.30	.20	.20
	750			2.10	1.40	.80	.60	.40	.40
	1,000			3.60	2.50	1.40	1.00	.80	.60
	1,500				5.40	3.10	2.10	1.60	1.30
	2,000					5.30	3.70	2.80	2.30
3/4" Schedule 40	500	.40	.40	.20	.20				
	1,000	1.60	1.30	.90	.60	.30	.20	.20	.20
	1,750			2.50	1.70	1.00	.70	.50	.40
	2,500			5.00	3.40	1.90	1.40	1.00	.80
	4,000					4.70	3.40	2.60	2.10
1" Schedule 40	1,000	.50	.40	.30	.20	.10			
	1,750	1.30	1.10	.70	.50	.30	.20	.20	.10
	2,500			1.40	1.00	.60	.40	.30	.20
	3,750			3.10	2.10	1.20	.80	.70	.50
	5,000				3.70	2.10	1.50	1.10	.90
1-1/2" Schedule 40	2,500	.30	.30	.20	.10				
	3,700	.70	.50	.40	.30	.10	.10		
	5,000	1.10	.90	.60	.40	.20	.20	.10	.10
	7,500		2.00	1.40	.90	.50	.40	.30	.20
	10,000			2.40	1.60	.90	.60	.50	.40
2" Schedule 40	3,750	.20	.20	.10					
	5,000	.30	.20	.20	.10				
	7,500	.70	.60	.40	.30	.20	.10		
	10,000	1.20	1.00	.70	.50	.30	.20	.10	.10
	12,500		1.50	1.00	.70	.40	.30	.20	.20
15,000			1.50	1.00	.60	.40	.30	.30	

### How to calculate Pressure Drop (Loss) in Pounds for Other Pipe Lengths:

- **Shorter Than 100 Feet**

The friction loss in pipe lengths shorter than 100 feet may be calculated proportional to the length.

**Example:** For 50 feet, 1/2 the charted figure.

- **Over 100 Feet**

In pipe runs of more than 100 feet, the same proportional method may be used providing the resultant friction loss does not exceed 10 PSIG.

**Example:** For 150 feet, 1-1/2 times the charted figure.

Unit Conversions	
<b>Pressure</b>	
PSI	= 14.5 X BAR
Pa	= 6,894.757 x PSI
KPa	= 6.894757 x PSI
PSI	= $\frac{\text{Pa}}{6894.757}$
PSI	= $\frac{\text{KPa}}{6.894757}$
<b>Flow</b>	
SCFH	= 2.118 x LPM
SCFH	= 60 x SCFM
LPM	= $\frac{\text{SCFH}}{2.118}$
<b>Units</b>	
PSI:	Pounds per Square Inch
Pa:	Pascal
KPa:	1000 Pascal
SCFH:	Standard Cubic Feet per Hour
SCFM:	Standard Cubic Feet per Minute
LPM:	Liters per Minute

**Dimensions for Center Section and Headers**

Manifold Type	Center Section Only	2 Headers	4 Headers	6 Headers
<b>Dual</b>	N/A	Fuel 26" All other 20" Fuel 65 cm All other 50 cm	N/A	N/A
<b>Simplex (SPLX)</b>	16.0 in 40.6 cm	Fuel 42" All other 36" Fuel 105.6 cm All other 90.6 cm	Fuel 68" All other 56" Fuel 170.6 cm All other 140.6 cm	Fuel 96" All other 76" Fuel 235.6 cm All other 190.6 cm
<b>Single (SSIN)</b>	16.0 in 40.6 cm	Fuel 42" All other 36" Fuel 105.6 cm All other 90.6 cm	Fuel 68" All other 56" Fuel 170.6 cm All other 140.6 cm	Fuel 96" All other 76" Fuel 235.6 cm All other 190.6 cm
<b>Non-Cabinet (SAM)</b>	32.0 in 81.2 cm	Fuel 58" All other 52" Fuel 146.2 cm All other 131.2 cm	Fuel 84" All other 72" Fuel 211.2 cm All other 181.2 cm	Fuel 110" All other 92" Fuel 276.2 cm All other 231.2 cm
<b>Liquid (LIQ)</b>	30.0 in 75 cm	Fuel 42" All other 36.5"	N/A	N/A
<b>VM</b>	13 in 33 cm	Fuel 38" All other 33" Fuel 97 cm All other 84 cm	Fuel 65" All other 53" Fuel 165 cm All other 135 cm	Fuel 91" All other 73" Fuel 231 cm All other 185 cm

**For Manifold questions call  
1-800-569-0547**

**UNITED STATES CUSTOMER SERVICE**  
**Phone: 1-800-569-0547 FAX: 1-800-569-0549**  
For International & Canada see back cover.

Visit our Web Site:  
<http://www.thermadyne.com>  
<http://www.victorhpi.com>

**U.S. Customer Care: 800-569-0547 / FAX 800-535-0557 • International Customer Care: 905-827-9777 / FAX 905-827-9797**  
**[www.victorhpi.com](http://www.victorhpi.com)**



***A Global Cutting & Welding Market Leader™***

**THE AMERICAS**

Denton, TX USA  
U.S. Customer Care  
Ph: (1) 800-426-1888  
Fax: (1) 800-535-0557

Miami, FL USA  
Sales Office, Latin America  
Ph: (1) 954-727-8371  
Fax: (1) 954-727-8376

Oakville, Ontario, Canada  
International Customer Care  
Ph: (1) 905-827-9777  
Fax: (1) 905-827-9797

Rio de Janeiro, Brazil  
Customer Care  
Ph: (55) 21-2485-8998  
Fax: (55) 21-2485-8866

West Lebanon, NH USA  
Customer Care, Plasma  
Ph: (1) 800-752-7621  
Fax: (1) 800-221-4401

**EUROPE**

Chorley, United Kingdom  
Customer Care  
Ph: (44) 1257-261755  
Fax: (44) 1257-224800

Milan, Italy  
Sales Office  
Ph: (39) 0236546801  
Fax: (39) 0236546840

**ASIA/PACIFIC**

Cikarang, Indonesia  
Customer Care  
Ph: 62 21+ 8983-0011 / 0012  
Fax: 62 21+ 893-6067

Osaka, Japan  
Sales Office  
Ph: 816-4809-8411  
Fax: 816-4809-8412

Melbourne, Australia  
Customer Care:  
Ph: 1300-654-674  
Fax: 613+ 9474-7391

International:  
Ph: 613+ 9474-7508  
Fax: 613+ 9474-7488

Rawang, Malaysia  
Customer Care  
Ph: 603+ 6092-2988  
Fax: 603+ 6092-1085

Shanghai, China  
Sales Office  
Ph: 86 21+ 6280-1273  
Fax: 86 21+ 3226-0955

Singapore  
Sales Office  
Ph: 65+ 6832-8066  
Fax: 65+ 6763-5812